

Pro-Ductor®

Insulated flat conductor bar
for 4, 7 or 10 conductors

Technical information

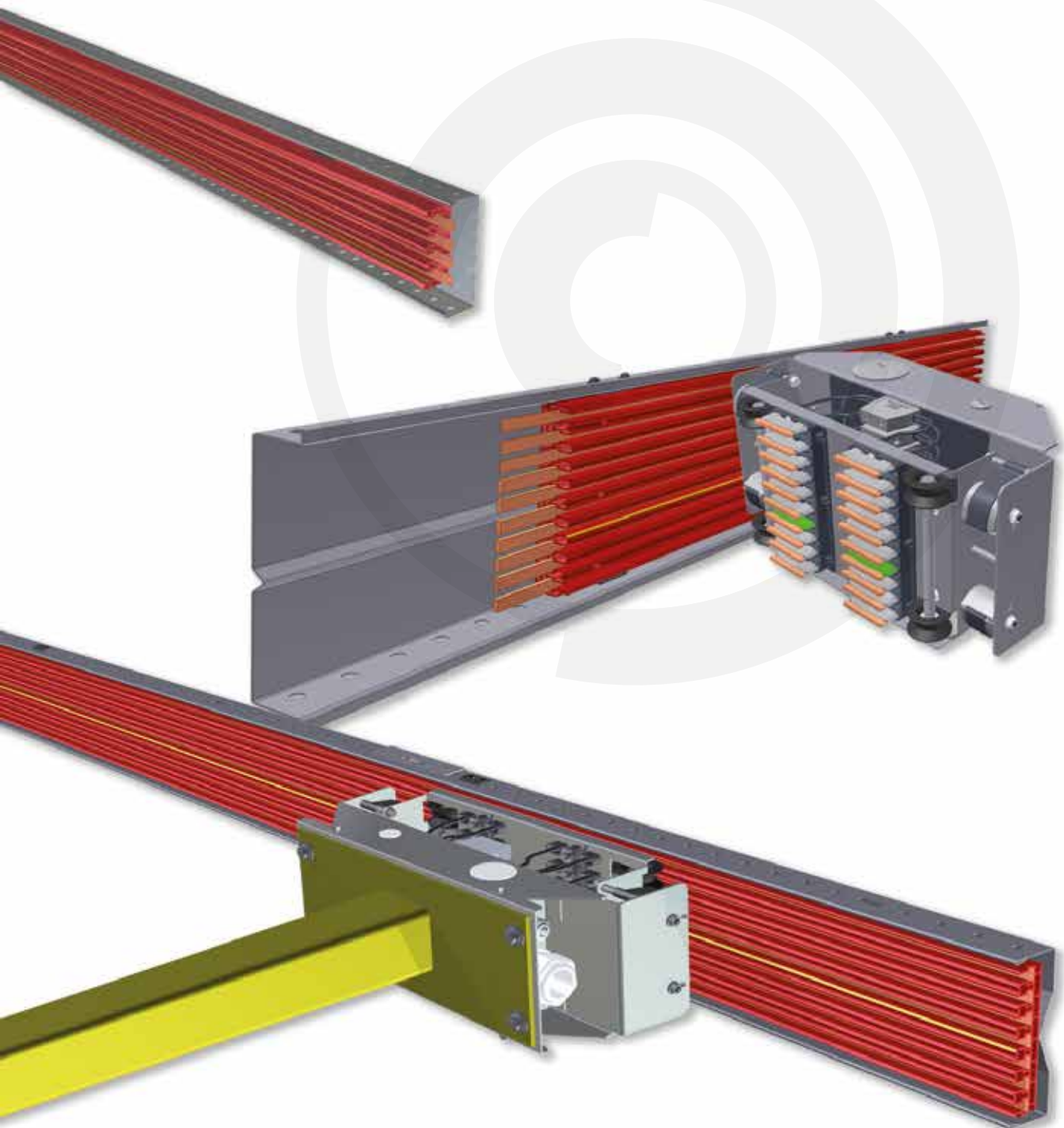

AKAPP Pro-Ductor®

- The ideal flat conductor system for automated warehouses and many other applications
- Current capacity 50A, 80A, 125A, 160A, 200A, 250A, 320A and 400A
- Housing up to 4, 7 or 10 uninterrupted conductors
- Usable at most heights
- Self-aligning collector trolleys
- High travel speeds up to 500 m/min possible.
- Highly suited to transmission of control and data signals
- Extremely low maintenance costs



AKAPP Pro-Ductor conductor system is a unique concept, permitting the ultimate in possibilities and applications.

Pro-Ductor is specifically designed for use in automated warehouses, that are characterised by a range of extremely challenging demands.

Pro-Ductor offers many possibilities. An example is illustrated (left). Here you can see a Pro-Ductor installation in an automated high bay warehouse with an aisle changing crane.

All data and versions mentioned in this brochure are subject to change without notice. No rights can be derived from this information in any way.

Wabtec Netherlands B.V. is not liable for damage resulting from the use of this information.

AKAPP Pro-Ductor[®] conductor bar systems: the ultimate in design!

Compact, dependable and secure power supply system featuring our unique continuous smooth copper conductors. Most suitable for utilising in (automatic) high-bay warehouses. AKAPP Pro-Ductor is ideally suited and proven for both control and data signal transmission.

This brochure provides a brief summary of the extensive possibilities of the Pro-Ductor system. For further information please visit our website: www.akapp.com.

To contact us directly, we refer to the front cover of this brochure for detailed information on our address.

Some important advantages:

Optimum reliability is assured by a number of advantages as described below.

Very low TCO

The Total Cost of Ownership is very low, because of the low maintenance costs and high reliability of the system.

Easy and quick installation

The steel support profiles (lengths 4 m each) are to be mounted directly to the adjusted uprights, which reduces the mounting time considerably. The profiles can be easily and quickly connected to each other.

The individual housing lengths (max. 4 m) can easily be connected to each other by means of joints with connection pins, without screwing or drilling. After this, the copper conductors are pulled through the channels.

No jointed connections

The best method to reduce voltage loss is an uninterrupted copper conductor. This is essential when it concerns reliable transmission of control signals. No problem whilst working with AKAPP!

4 (PR4), 7 (PR7) or 10 (PR10) copper channels

Due to the clearance between the conductors and their location, the copper channels offer sufficient room for up to 10 uninterrupted conductors, without plug connectors. Ideally suited for both control and data signal transmission.

5 different types of copper conductors

The flat copper conductors are available in 50A, 80A, 125A, 160A and 200A (80% D.C.).

High current options

Parallel-mounted systems provide a maximum current capacity of 400A (80% D.C.)! Above that, copper conductors for control signals can be added when applying the 10-pole profile PR10.

Capacity extendable

The installation can be extended at all times and at any moment. For instance, due to a changed situation additional or heavier copper conductors can be installed until the maximum number of slots is reached.

No expansion problems

The copper conductors lie separately in each channel, so that these can expand and contract independently of the PVC housing.

Wheel guide construction

The perfect guide construction optimizes the electrical contact of the carbon brushes with the copper conductors and reduces wear. Above this, it prevents carbon moisture within the housing (unlike pantograph based systems). The wheel guide construction enhances the life expectancy of the collector trolleys and brushes.

Compact construction

With inclusion of the support profile SP4, the system measures 46 x 128 mm; for profile SP7 this is 45 x 165 mm; for profile SP10 this is 40 x 240 mm. Suitable for most automated warehouses. Furthermore it can be installed, virtually at floor level!

Approvals and certifications

Pro-Ductor types PR4, PR7 and PR10 are CE-approved and UL-certified.

Feed and control in a single housing

Combine the feed strips with those for control, separating them safely with the ground conductor strip.

Uninterrupted yellow/green earth-marking

Clearly indicates the earth conductor. Safety!

Safety first!

The PVC-housing is self-extinguishing and has a conspicuous red colour for additional safety. Furthermore the housing is contact safe (IP2XB according to the standard IEC 60529).

AKAPP Pro-Ductor offers easy and fast mounting, safety to personnel, high reliability, low maintenance and an advantageous total life-time cost!

Pro-Ductor[®] systems PR4, PR7 and PR10: combine flexibility with reliability!

The Pro-Ductor system is specifically designed for heavy duty tasks performed in automated warehouses.

The standard housing length is 4 metre. Any length less than 4 metres is possible. Connecting the sections is done using the click and lock system. No drilling or screws!

Up to 4 conductors can be positioned in the channels within the PVC conductor housing PR4; up to 7 conductors within the PVC conductor housing PR7 up to 10 conductors within the PVC conductor housing PR10.

The number and capacity of the conductors depend on the requirements.

It is possible to combine conductors for feed and control. The PR10 housing makes it possible to combine parallel switched conductors for very high current applications with conductors for control functions.

More details on page 5.

The most important details of the housings PR4, PR7 and PR10 are described in the section below.

Railhousings

Type PR4

with 4 channels for up to 4 uninterrupted, loosely spaced conductors.

Color: signal red.

Temperature range: from -30 °C up to +60 °C.

A continuous yellow/green marking on the housing ensures correct fitting of the system. The PVC with a high impact strength is self extinguishing.

Type PR7

with 7 channels for 4 up to 7 uninterrupted, loosely spaced conductors.

Color: signal red.

Temperature range: from -30 °C up to +60 °C.

A continuous yellow/green marking on the housing ensures correct fitting of the system. The PVC with a high impact strength is self extinguishing.

Type PR10

with 10 channels for 6 up to 10 uninterrupted, loosely spaced conductors.

Color: signal red.

Temperature range: from -30 °C up to +60 °C.

A continuous yellow/green marking on the housing ensures correct fitting of the system. The PVC with a high impact strength is self extinguishing.

Technical data of housings

Material

Unplasticized Hard-PVC with approximate values:

Notch shock strength	5-10 kJ/m ²
E-modulus	2500-3000 N/mm ²
Softening point (Vicat)	81-83°C
Linear expansion	70.10 ⁻⁶ m/m/°C

Electrical data

Volume resistivity with 100 V	>4.10 ¹⁵ Ω/cm
Dielectric strength with 50 Hz	>30 kV/mm
Flame class UL94	V0

Length of housing 4 m standard

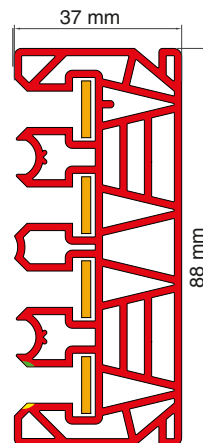

Housing PR4 with copper conductors

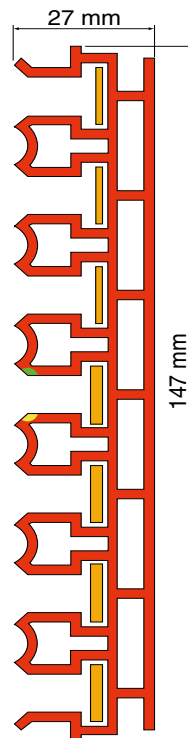

Housing PR7 with copper conductors

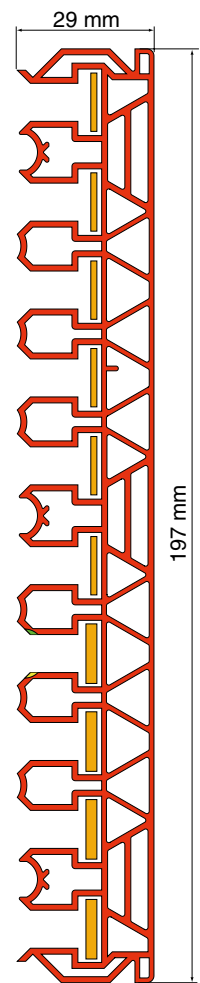

Housing PR10 with copper conductors

AKAPP ART. NO.	DESCRIPTION	linear exp. 10 ⁻⁶ m/m/°C	min. temp. °C	max. temp. °C	combined with transfer guides
2020010	PVC housing, red PR4	70	-30	60	
2001080	PVC housing, red PR7	70	-30	60	x
2030010	PVC housing, red PR10	70	-30	60	x

Ultimate logistical control: uninterrupted feed at all times

Each Pro-Ductor installation is supplied with the joint-free flat copper conductors, rolled on and based on track length. Copper strips are available for current intensities of **50, 80, 125, 160 and 200A** (D.C. 80%). Material: electrolytic copper.

When 2 strips are parallel connected for each of the 3 phases of a three-phase system, current intensities of **250A** (2x125), **320A** (2x160) and **400A** (2x200) are possible.

The 7th conductor being utilised as earth supply.

The order of the copper channels in the Pro-Ductor housing referring to the line feed clamp holders LCH and collector trolleys PCT can be viewed on the drawings on page 20, 21 and 22.

Partially due to the joint-free conductors the Pro-Ductor is **well suited for control current and data transfer**; especially when using silver-plated conductors.

Contact your AKAPP supplier on this subject.

Special material conductors

The concept of the Pro-Ductor system allows the application of other metal apart from copper. For example silver-plated copper (advantageous for data transfer!).

Installation of the copper conductors

Following the installation of the conductor housings the flat copper conductors can easily be pulled into the copper channels directly from the cable drum. This can be easily and quickly effected by means of the copper pulling cassette and drawing device, available as an option.

A simple straightener is supplied for conductors CU125, CU160 and CU200. This is designed to make installation easier and also to reduce any resistance on very long installations.

Voltage drop in copper conductors. By virtue of the continuous conductor concept, the voltage drop in an AKAPP Pro-Ductor system is kept to an absolute and constant minimum. With a power factor (cos. φ) of < 1 the figures mentioned in the adjacent table have to be changed accordingly, e.g. with $\cos \varphi = 0.85$ the voltage drop figures have to be multiplied by 0.85.

Arrangement of the copper conductors

A large number of combinations is possible, using the standard housings and 5 different copper conductors. Below some examples with PR7 and PR10 systems.

50A	
80A	
125A	
160A	
200A	



For applications where higher temperatures exist, the resistance, and therefore the voltage drop, increases.

Solution: using next size copper conductors.

Voltage drop in V/metre Pro-Ductor/A nominal current, cos. $\varphi=1$, ambience temperature +20°C		
copper conductor	3 phase ~	1 phase ~ and =
Cu50	0.00339	0.00391
Cu80	0.00217	0.00251
Cu125	0.00119	0.00138
Cu160	0.00092	0.00106
Cu200	0.00068	0.00069

When utilizing 2 copper conductors in parallel the voltage drop values in the table will be halved.

On request, impedance data can be supplied.

with +35 °C multiply with 1.079
with +45 °C with 1.118
with +55 °C with 1.157

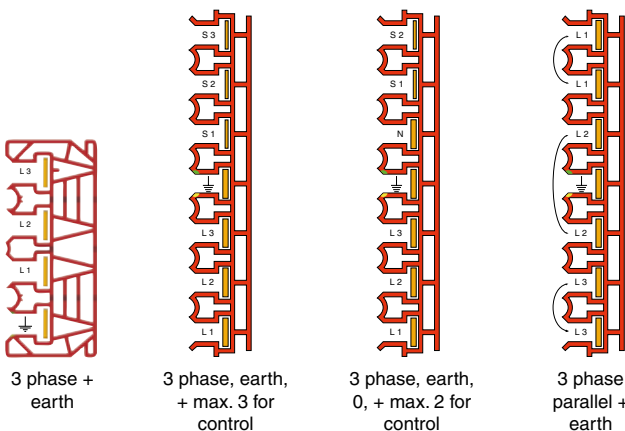

3 phase, earth,
0, + max. 5 for
control



3 phase parallel,
earth + max. 3
for control



3 phase parallel,
earth, 0 + max. 2
for control

AKAPP ART. NO.	DESCRIPTION	max In (ID=80%) A	dimension (b x d) mm	cross section mm ²	copper weight kg/m	DC resistance Ω /m	max. length copper roll m
1002560	Copper conductor 50A CU50	50	12.6 x 0.7	8.82	0.078	0.00198	525
1002640	Copper conductor 80A CU80	80	12.5 x 1.1	13.75	0.120	0.00127	325
1002720	Copper conductor 125A CU125	125	12.5 x 2.0	25.00	0.219	0.0007	200
1002870	Copper conductor 160A CU160/7	160	12.5 x 2.6	32.50	0.284	0.000538	150
1002910	Copper conductor 200A CU200/7	200	12.5 x 4.0	50.00	0.440	0.000344	100
1003370	Copper conductor silv. 50A CU50/AG	50	12.6 x 0.7	8.82	0.078	0.002	525

Mounting of housings PR4: without or with the steel support profile

AKAPP Pro-Ductor housings PR4 **can be mounted directly to the uprights**. The support distance reaches 0.8m max. Applying the steel support profile SP4 however offers support distances up to 3300 mm between the uprights. While using the support profile, the PVC housing is optimally protected against mechanical damage (e.g. falling objects) which increases the reliability of the system.

The support profile can, in most cases, be mounted directly to the storage racks, without extra construction parts. However, it may occur that you need to mount the support profile in a

different way. Information on alternative possibilities of mounting the support profile can be found on page 10 and 11.

Fast and easy mounting of the insulated Pro-Ductor housing is possible without using screws. (see drawing).

In most cases the Pro-Ductor system will be installed horizontally, with the conductors below one another. Mounting of the Pro-Ductor system vertically is also possible. We strongly recommend you to contact Wabtec Netherlands for technical advice in such a situation.

Mounting of PR4 without support profile

For mounting of the pvc housing PR4 directly to the uprights **without the steel support profile SP4**, the mounting bracket PR4-MB is to be used. See figure below. Support distance max. 0.8 m.

Mounting of the support profile SP4

Mounting bracket type SP4-MB

There are several ways of mounting the brackets to a construction. In most cases, the brackets can be mounted directly on to the storage racks by means of a bolt through the hole in the bracket and the upright. The maximum support distance depends on the number of collector trolleys:

QTY	DESCRIPTION	MAX. SUPPORT DISTANCE A
1 pc.	Collector trolley PCT4-x-125	3300 mm
2 pc.	Collector trolleys PCT4-x-125	2750 mm

Attention: When using support posts, different support distances must be respected, see page 9.

Support profile type SP4

Galvanised steel, with mounting holes for mounting brackets and joint clamps.

Standard length 4 metre. Lengths less than 4 metre possible.

The shape of the support profile combines high rigidity with a low weight and minimal sizes. Above that it prevents bending of the PVC housing through pressure of the carbon brushes from the collector trolley.

The sections are fitted with punched holes that allow positioning of mounting clips (see picture below) for easily fixing the housing PR4 without any tools. Per 0.8 metre, 1 mounting clip is needed (to be ordered separately).

The PVC housing is supported over the entire track length, which results in high stability of the system. This makes very high travel speeds possible. **Attention:** both system ends require extra length support profile due to expansion of the pvc housing. Please see drawing on page 29.

Joint clamp type SP4-JC

The joint clamp is slid from the back side of the support profiles and fitted through 4 slot holes on the top and bottom of the clamp that correspond with holes in the support profiles.

AKAPP ART. NO.	DESCRIPTION	TYPE
2020030	Support profile for PR4 SP4 L = 4 m	SP4
2040660	Mounting bracket for SP4, complete	SP4-MB
2040510	Mounting clip for PR4	PR4-MC
2040690	Mounting bracket with M6x20 bolt	PR4-MB-M6x20
2040695	Mounting bracket with self drilling screws	PR4-MB-SDS
2040700	Mounting bracket w. glide nut f. support post	PR4-MB-S
2040685	Joint clamp for SP4, complete	SP4-JC

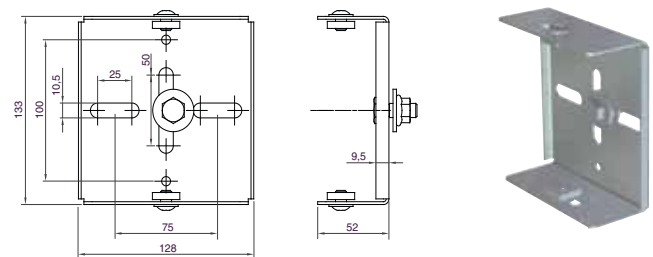

Mounting bracket SP4-MB

Suspending SP4

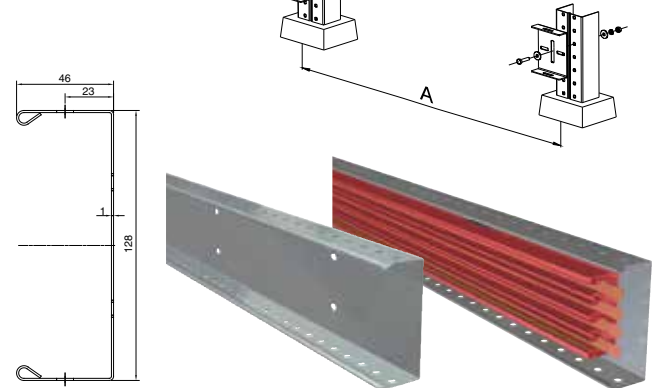

Support profile for housing PR4

Support profile with housing PR4

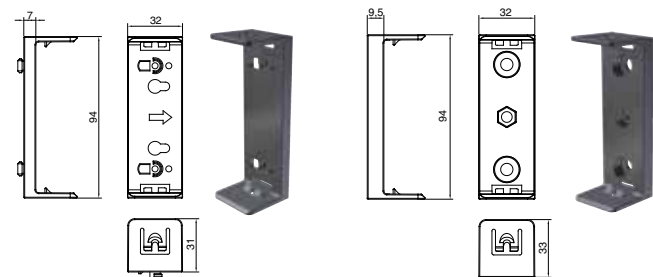

Mounting clip PR4-MC (for mounting with SP4)

Mounting bracket PR4-MB (for mounting without SP4)



Joint clamp SP4-JC

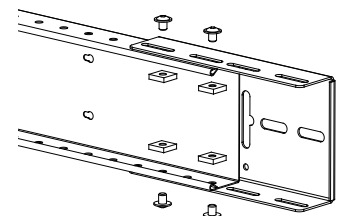

Connection of support profile SP4 with joint clamp SP4-JC

Mounting of steel support profile SP7: always a perfect support!

AKAPP Pro-Ductor housings PR7 are situated within the steel support profile SP7. Applying this profile offers support distances up to 3300 m between the uprights.

The PVC housing is optimally protected against mechanical damage (e.g. falling objects), which increases the reliability of the system.

The support profile can, in most cases, be mounted directly to the storage racks, without extra construction parts. However, it may occur that you need to mount the support profile in a different way.

Information on alternative possibilities of mounting the support profile can be found on pages 10 and 11.

Fast and easy mounting of the insulated Pro-Ductor housing is possible without using screws. (see drawing).

In most cases the Pro-Ductor system will be installed horizontally, with the conductors below one another. Mounting of the Pro-Ductor system vertically is also possible. We strongly recommend you contact Wabtec Netherlands for technical advice in such a situation.

Suspension of the support profile SP7

Mounting bracket type SP7-MB

There are several ways of mounting the brackets to a construction. In most cases, the brackets can be mounted directly on to the storage racks by means of a bolt through the hole in the bracket and the upright. The maximum support distance depends on the number of collector trolleys:

QTY	DESCRIPTION	MAX. SUPPORT DISTANCE A
1 pc.	Collector trolley PCT7-x-125	3300 mm
2 pc.	Collector trolleys PCT7-x-125	2750 mm

Attention: When using support posts, different support distances must be respected, see page 9.

Special mounting brackets for **transfer sections** see page 24.

Support profile type SP7

Galvanised steel, with mounting holes for mounting brackets and joint clamps.

Standard length 4 metre. Lengths less than 4 metre possible.

The steel support profile can easily be mounted to the uprights. With the housing in vertical position (conductors below each other), the minimal mounting height is 200 mm (top of PCT7 trolley).

The shape of the support profile combines high rigidity with a low weight and minimal sizes. Above that it prevents bending of the PVC housing through pressure of the carbon brushes from the collector trolley.

The sections are fitted with punched holes that allow positioning of mounting clips (see picture below) for easily fixing the housing PR7 without any tools. Per metre, 1 set of mounting clips (top and bottom) is needed (to be ordered separately).

The PVC housing is supported over the entire track length, which results in high stability of the system. This makes very high travel speeds possible. **Attention:** both system ends require extra length support profile due to expansion of the pvc housing. Please see drawing on page 30.

Joint clamp type SP7-JC

The joint clamp connects 2 support profile sections SP7. It is slid from the back side of the support profiles and fitted through 4 slot holes on the top and bottom of the clamp that correspond with holes in the support profiles.

Every joint clamp comes with square nuts and socket head screws for fixing.

AKAPP ART. NO.	DESCRIPTION	TYPE
2010200	Mounting bracket for SP7, complete	SP7-MB
2010100	Support profile for PR7 SP7 L = 4 mtr	SP7
2010400	Mounting clip for PR7, top	PR7-MCT
2010450	Mounting clip for PR7, bottom	PR7-MCB
2010250	Joint clamp for SP7, complete	SP7-JC

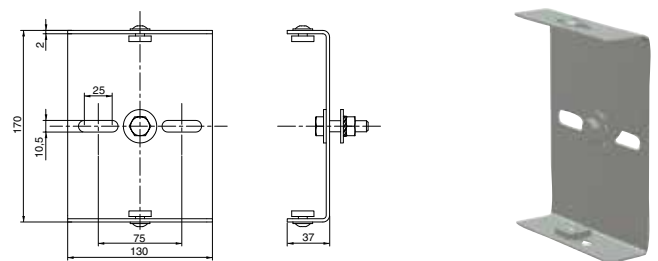

Mounting bracket SP7-MB

Suspending SP7

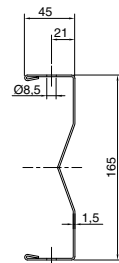
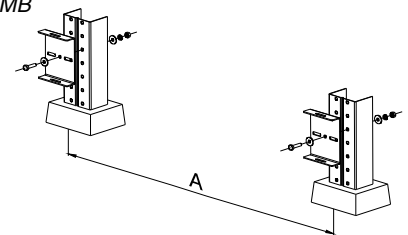

Support profile for housing PR7

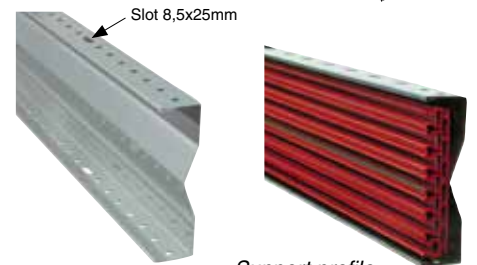

Support profile with housing PR7

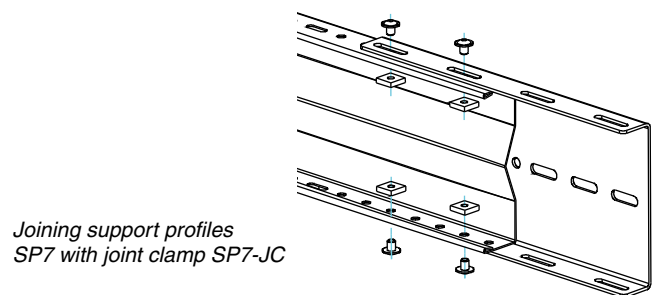

Joining support profiles SP7 with joint clamp SP7-JC

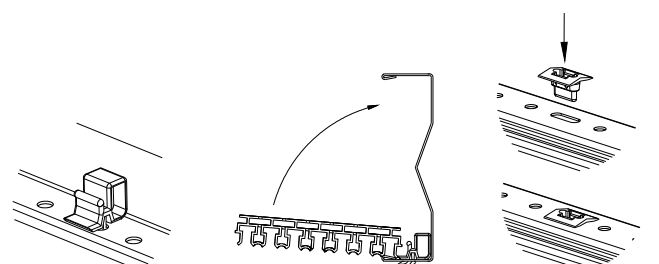

Mounting clip PR7-MCB at the bottom of SP7

Mounting PR7 after placing mounting clips PR7-MCB

Mounting clip PR7-MCT on top of SP7

Mounting of steel support profile SP10: the solid base of a compact system!

AKAPP Pro-Ductor housings PR10 are situated within the steel support profile SP10. Applying this profile offers support distances up to 3300 m between the uprights.

The PVC housing is optimal protected against mechanical damage (e.g. falling objects), which increases the reliability of the system.

The support profile can, in most cases, be mounted directly on to the storage racks, without extra construction parts. However, it may occur that you need to mount the support profile in a different way.

Information on alternative possibilities of mounting the support profile can be found on page 10 and 11.

Fast and easy mounting of the insulated Pro-Ductor housing is possible without using screws. (see drawing).

In most cases the Pro-Ductor system will be installed horizontally, with the conductors below one another. Mounting of the Pro-Ductor system vertically is also possible. We strongly recommend you contact Wabtec Netherlands for technical advice in such a situation.

Suspension of the support profile SP10

Mounting bracket type SP10-MB

There are several ways of mounting the brackets to a construction. In most cases, the brackets can be mounted directly to the storage racks by means of a bolt through the hole in the bracket and the upright. The maximum support distance depends on the number of collector trolleys:

QTY	DESCRIPTION	MAX. SUPPORT DISTANCE A
1 pc.	Collector trolley PCT10-x-125	3300 mm
2 pc.	Collector trolleys PCT10-x-125	2750 mm

Attention: When using support posts, different support distances must be respected, see page 9.

Support profile type SP10

Galvanised steel, with mounting holes for mounting brackets and joint clamps.

Standard length 4 metre. Lengths less than 4 metre possible.

The steel support profile can easily be mounted to the uprights. With the housing in vertical position (conductors below each other), the minimal mounting height is 275 mm (top of the PCT10 trolley).

The shape of the support profile combines high rigidity with a low weight and minimal sizes. Above that it prevents bending of the PVC housing through pressure of the carbon brushes from the collector trolley.

The sections are fitted with punched holes that allow positioning of mounting clips (see picture below) for easily fixing the housing PR10 without any tools. Per metre, 2 mounting clips (top and bottom) are needed (to be ordered separately).

The PVC housing is supported over the entire track length, which results in high stability of the system. This makes very high travel speeds possible. **Attention:** both system ends require extra length support profile due to expansion of the pvc housing. Please see drawing on page 30.

Joint clamp type SP10-JC

The joint clamp connects 2 support profile sections SP10. It is slid from the back side of the support profiles and fitted through 4 slot holes on the top and bottom of the clamp that correspond with holes in the support profiles.

Every joint clamp comes with square nuts and socket head screws for fixing.

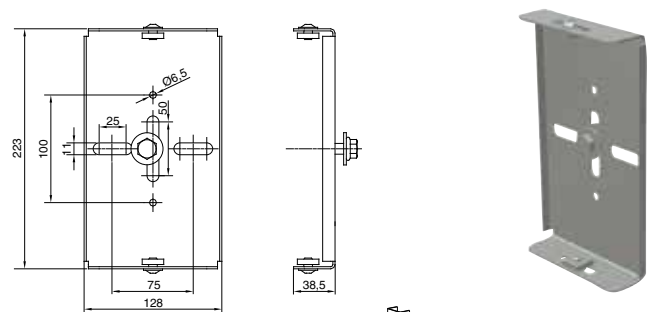

Mounting bracket SP10-MB

Suspension of SP10

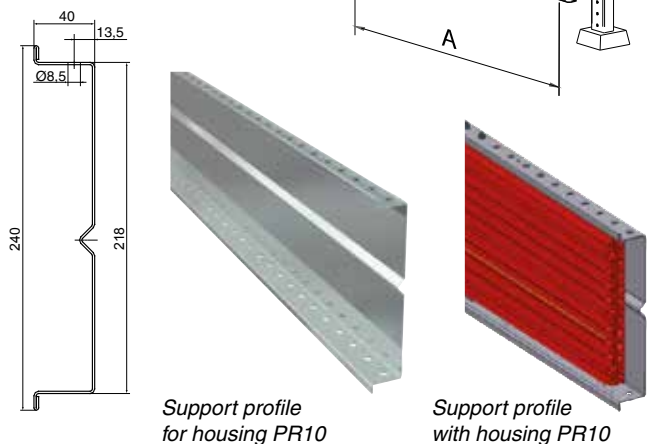

Support profile for housing PR10

Support profile with housing PR10

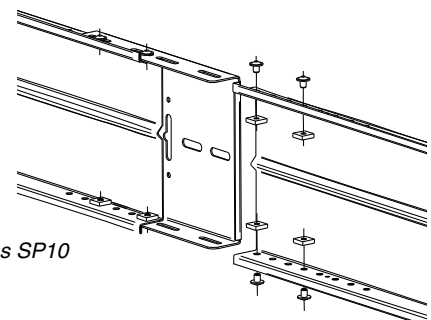

Joining support profiles SP10

AKAPP ART. NO.	DESCRIPTION	TYPE
2030101	Mounting bracket, including fasteners	SP10-MB
2030055	Support profile, L=4 metre	SP10
2030106	Joint clamp, complete	SP10-JC
2030500	Mounting clip	PR10-MC

Mounting clips (bottom and top) for SP10

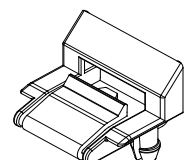

AKAPP Pro-Ductor[®] conductor systems: supporting the suspension

The support profiles SP4, SP7 or SP10 can, in most cases, be mounted directly on to the storage racks, without extra construction parts.

However, it may be that you need you need extra supports or that you have to mount the support profile in an alternative way.

If extra supports are needed, e.g. because the distance between the storage racks is too wide, you can choose the standard support posts that AKAPP offer.

Please see details below.

If alternative suspension of the support profile is needed, please see more detailed information on pages 10 and 11.

For other solutions, further information or advise, you can contact our office. The references are listed on the front page of this brochure.

Suspension to support posts

The steel support profile (standard length 4 m) is easily fixed to the storage racks. In most cases the rail will be installed with the conductors below one another).

If there are not enough uprights, the support profile can be suspended to support posts. In that case, the maximum centre distance between the posts should be 2900 mm (when SP7-P600 is applied).

Standard support posts are available with height of 600 mm. Other heights on request. See drawing and table for details.

AKAPP ART. NO.	DESCRIPTION	TYPE
2003050.B0006	Support post h=600 Including fastening materials	SP7-P600

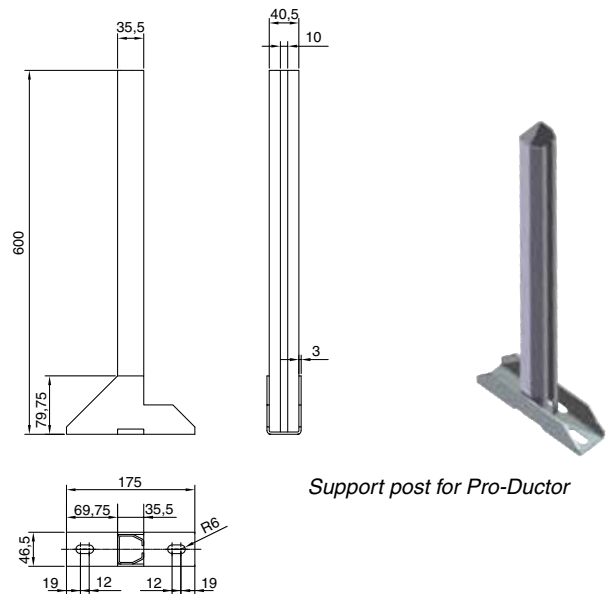

Support post for Pro-Ductor

The maximum allowed centre distance of the mounting brackets depends on the height of the support posts and the number of collector trolleys, as shown in the table below.

SUPPORT POST TYPE	DESCRIPTION	MAX. CENTRE DISTANCE (A)
SP7-600	1 pc. Collector trolley 125A	2900 mm
SP7-600	2 pc. Collector trolleys 125A	2400 mm

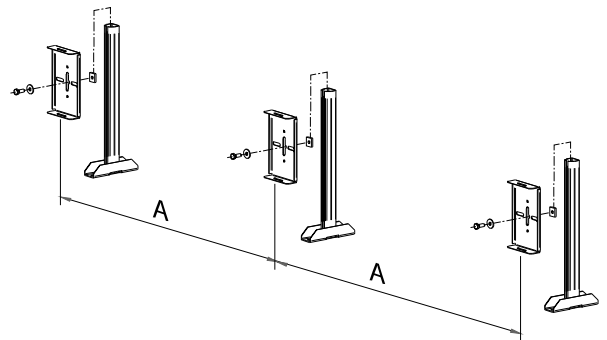

Feed and control for warehouse crane in deep freeze storage



Pro-Ductor system for high speed operation

AKAPP Pro-Ductor[®] conductor systems: alternative ways of suspension

AKAPP Pro-Ductor systems will generally be mounted to the storage racks of a (high-bay) warehouse. Alternatively, (extra) support posts can be applied if the span between the racks is too wide to guarantee a stable system.

See page 9 for more information on this.

There are however more ways of suspension.

You can use self drilling screws, e.g. for applications where a bolt with nut can not be used.

See the detailed information below.

There is also a possibility for suspension with clamp constructions, enabling suspension without drilling in uprights, or mounting on HEA-profiles. See page 11 for more information on this.

Alternative mounting with self-drilling screws

Type SP4-MB/SDS

Mounting brackets with self drilling screws for mounting to uprights without nuts. The 2 drill holes \varnothing 6 mm, provided in the mounting bracket, are used.

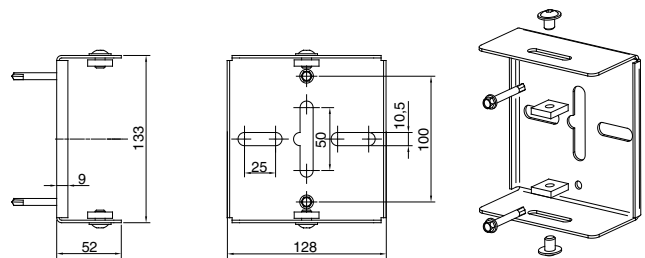

SP4-MB/SDS

Type SP7-MB/SDS

Mounting brackets with self drilling screws for mounting to uprights without nuts. The 2 drill holes \varnothing 6 mm, provided in the mounting bracket, are used.

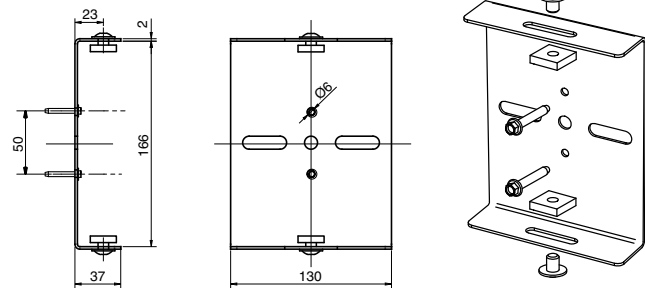

SP7-MB/SDS

Type SP10-MB/SDS

Mounting brackets with self drilling screws for mounting to uprights without nuts. The 2 drill holes \varnothing 6,5 mm, provided in the mounting bracket, are used.

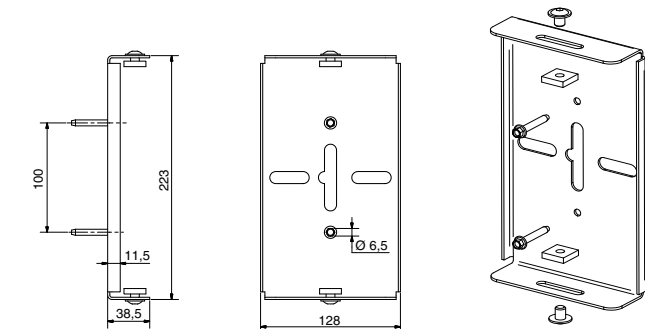

SP10-MB/SDS

AKAPP ART. NO.	DESCRIPTION	TYPE
2040695	Mounting bracket f. SP4 w. self drilling screw 5,5x19	SP4-MB/SDS
2010190	Mounting bracket f. SP7 w. self drilling screw 5,5x19	SP7-MB/SDS
2030102	Mounting bracket f. SP10 w. self drilling screw 5,5x19	SP10-MB/SDS

AKAPP Pro-Ductor[®] conductor systems: alternative ways of mounting

AKAPP Pro-Ductor systems will generally be mounted to the storage racks of a (high-bay) warehouse. Alternatively, (extra) support posts can be applied if the span between the racks is too wide to guarantee a stable system. See page 6 for more information on this.

There are however more ways of mounting.

Below, the special options with clamp constructions are described.

You can use mounting brackets for mounting to uprights without drilling, or clamps for mounting to HEA-profiles. Applicable for PR4 and PR7 systems.

See detailed information below.

Alternative mounting with clamps

Mounting systems for closed uprights

Type SPx-MBC...

Mounting bracket with clamp construction for suspension to storage racks without drill holes. The supplied C-profile is fixed with 2 bolts M8 (not included) and square nuts. Available for clamp widths (A) up to 90, 190 and 300 mm.

The length of the M8 bolts is determined by the width of the upright (dimension 'C'). See drawing next.

TYPE Mounting bracket	Clamp dimension between bolts A (mm)	Width mounting bracket B (mm)	Height mounting bracket D (mm)
SP4-MBC90	40 - 90	130	133
SP4-MBC190	90 - 190	240	133
SP4-MBC300	190 - 300	360	133
SP7-MBC90	40 - 90	130	170
SP7-MBC190	90 - 190	240	170
SP7-MBC300	190 - 300	360	170

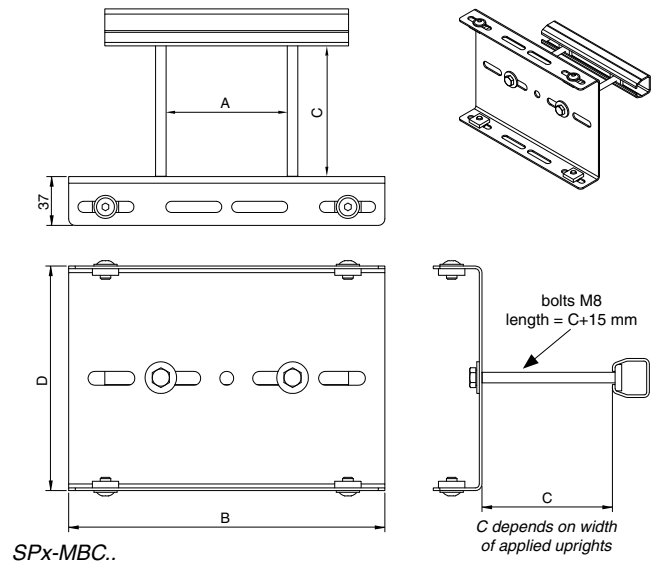

Mounting systems for HEA-profiles

Type SP4-MBC-HEA260

This suspension system, including the mounting bracket SP4-JC with clamps, is used for mounting support profile SP4 to uprights limited to HEA 260, if welding is not prohibited.

The bracket is to be mounted by means of the included clamps.

Dimension D = 133 mm

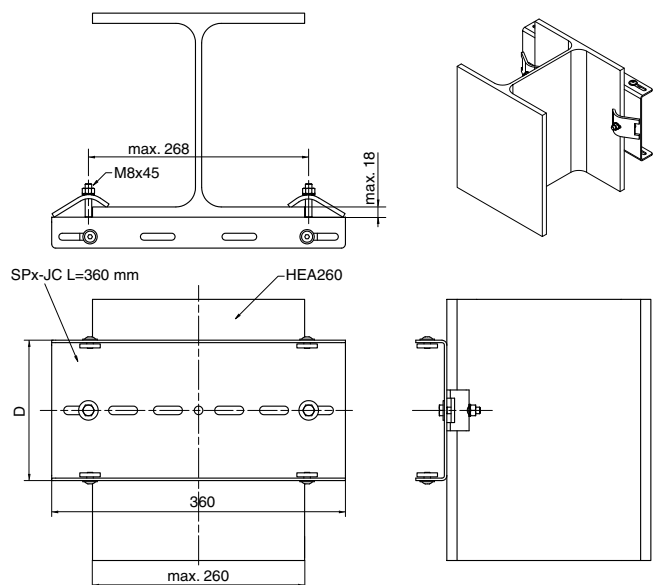

SP4-MBC-HEA260 - D = 133 mm
SP7-MBC-HEA260 - D = 170 mm

Type SP7-MBC-HEA260

This suspension system, including the mounting bracket SP7-JC with clamps, is used for mounting support profile SP7 to uprights limited to HEA 260, if welding is not prohibited.

The bracket is to be mounted by means of the included clamps.

Dimension D = 170 mm

AKAPP ART. NO.	DESCRIPTION	TYPE
2040670	Mounting bracket f. SP4 40-90 mm clamping	SP4-MBC90
2040672	Mounting bracket f. SP4 90-190 mm clamping	SP4-MBC190
2040675	Mounting bracket f. SP4 190-300 mm clamping	SP4-MBC300
2005020	Mounting bracket f. SP7 40-90 mm clamping	SP7-MBC90
2005030	Mounting bracket f. SP7 90-190 mm clamping	SP7-MBC190
2005040	Mounting bracket f. SP7 190-300 mm clamping	SP7-MBC300
2040680	Mounting bracket f. SP4 clamping for max. HEA260	SP4-MBC-HE260
2005010	Mounting bracket f. SP7 clamping for max. HEA260	SP7-MBC-HE260

Mounting housings: easily connecting of the housings

Housings PR4, PR7 and PR10 are connected to each other using joint sets, mounted at the back side of the housings.

After connecting all housings, it is important to make a fixation of the PVC housing with the steel support profile by means of a fixed point, located at the end or line feed.

From this fixed point, the PVC housing can expand and shrink freely into the support profile while sliding over the mounting clips (see page 6, 7 and 8).

At the end of each Pro-Ductor system an end rail (PR7) or end cap (PR4, PR10) is mounted.

Detailed information on this and the required components are described in the section on page 13.

Joining housings PR4, PR7, PR10

Joint sets

Type PR4-J

A complete set PR4-J contains a joint and 4 joint pins to make a connection between two PR4 profiles. The joint is slid into the slots of the profiles. When the holes in the strips correspond with the holes in the profiles, the joint pins can be mounted. This ensures a firm connection.

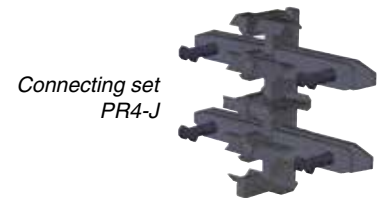
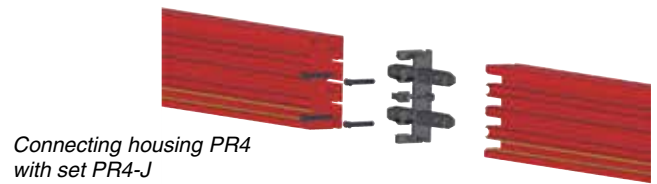

Type PR7-J

A complete set PR7-J contains 2 joint strips (PR7-JS) and 4 joint pins (PR7-JP) to make a connection between two PR7 profiles. Joint strips are slid into the slots of the profiles. When the holes in the strips correspond with the holes in the profiles, the joint pins can be mounted. This ensures a firm connection.

Connecting housing PR7 with set PR7-J

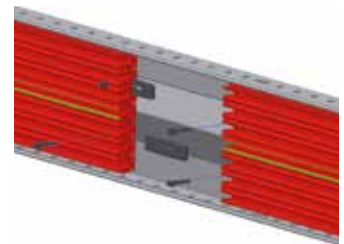

Type PR10-J

A complete set PR10-J contains a joint and 6 joint pins to make a connection between two PR10 profiles. Mounting is equal to set PR4-J.

Connecting housing PR10 with set PR10-J

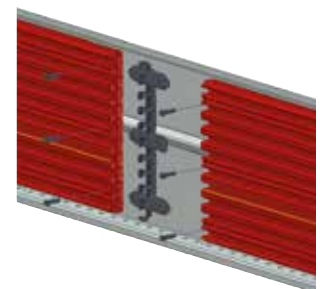

AKAPP ART. NO.	DESCRIPTION	TYPE
2040705	Set for PR4 joint	PR4-J
2010500	Set for PR7 joint	PR7-J
2030510	Set for PR7 joint	PR10-J

Mounting housings: finishing the system

At the end of each Pro-Ductor system an end cap set (Type S-ER4, S-ER7 or S-ER10) is mounted. Here the copper conductors can move freely when they expand or shrink through temperature changes.

The black end caps with end strips provide smooth finishing of the ends of both the PVC rail housing and the support profile.

Detailed information on this and the required components are described in the section below.

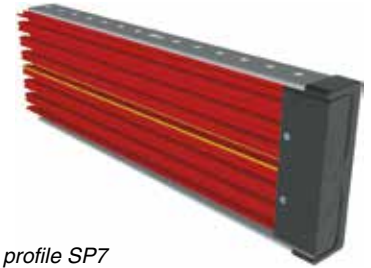

*End cap set S-ER7,
mounted, with support profile SP7*

End cap sets

Set End cap Type S-ER4

Each PR4 system requires 1 set end cap, containing an end rail (length 300 mm), 2 pcs end covers for housing PR4 and 2 pcs end strips for support profile SP4 (see picture).

The end rail catches the expansion of the copper conductors. At the other side of the system there should be approx. 250 mm extra housing for eliminating copper expansion.

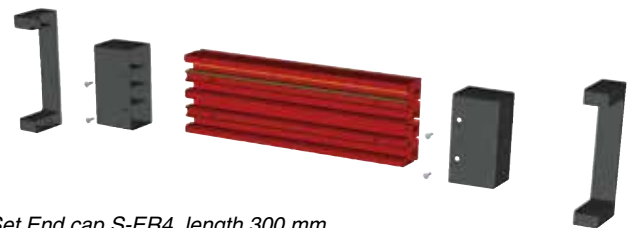

Set End cap S-ER4, length 300 mm

Set End cap Type S-ER7

Each PR7 system requires 1 set end cap, containing an end rail (length 300 mm), 2 pcs end covers for housing PR7 and 2 pcs end strips for support profile SP7 (see picture).

The end rail catches the expansion of the copper conductors. At the other side of the system there should be approx. 250 mm extra housing for eliminating copper expansion.

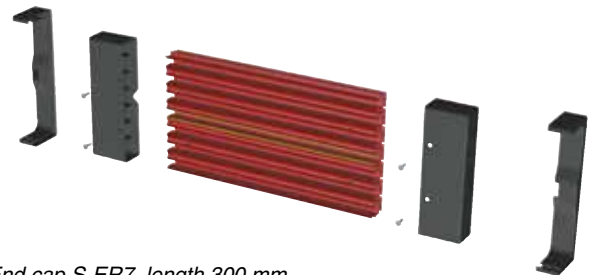

Set End cap S-ER7, length 300 mm

Set End cap Type S-ER10

Each PR10 system requires 1 set end cap, containing an end rail (length 300 mm), 2 pcs end covers for housing PR10 and 2 pcs end strips for support profile SP10 (see picture).

The end rail catches the expansion of the copper conductors. At the other side of the system there should be approx. 250 mm extra housing for eliminating copper expansion.

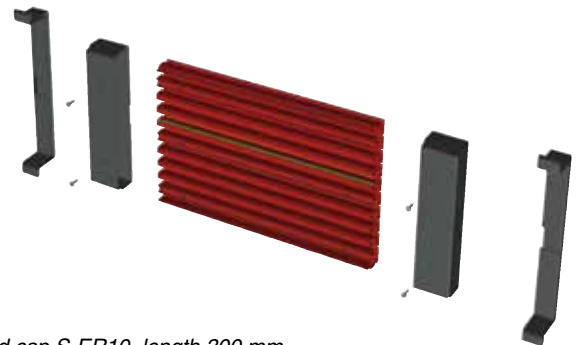

Set End cap S-ER10, length 300 mm

AKAPP ART. NO.	DESCRIPTION	TYPE
2040745	Set End cap PR4 L=300mm	S-ER4
2001800	Set End cap PR7 L=300mm	S-ER7
2030525	Set End cap PR10 L=300mm	S-ER10

Feed boxes for PR4: practical and easy ways to connect!

There are several possibilities for connecting feed- and control cables to a Pro-Ductor installation.

The cables can either be connected to the end of the Pro-Ductor installation (end feed) or at a chosen point in the installation (line feed).

In most cases, a line feed can be applied as an end feed.

The **order** of the **copper channels** in the Pro-Ductor housing referring to the line feed clamp holders LCH and collector trolleys PCT can be viewed on the drawing on page 20.

When parallel mounting of the copper conductors is needed, e.g. to increase the maximum current capacity or to decrease the voltage drop, then you should use Pro-Ductor PR7, applying the line feed solutions as shown on pages 5 and 18.

Alternatively, you can use the Pro-Ductor PR10 system featuring 10 copper channels. It offers sufficient space for parallel mounted conductors for feed, combined with conductors for control functions.

See detailed information on page 17.

Feed boxes for Pro-Ductor PR4.

Line feed (normal connection):

Connects the feed cable (and/or control cable) to the end of, or at a chosen point in, a Pro-Ductor system (see picture beside).

This feed box comes with a clamp holder (PR4-LCH), needed for mounting between two rail housing ends. In this clamp holder, the required feed clamps - to be ordered separately- are inserted (see page 18).

The copper conductors can be connected easily and safely to the feed clamps. The copper conductors will not be interrupted! Also, a set connection strips (CS) to connect the steel support profile ends at both sides of the clamp holder is included.

Please note that all feed clamps and connectors are not included and must be ordered separately, depending on your copper configuration (see page 18).

The feed box is fitted with cable glands M63 (cable entry up to Ø44,5 mm) and M20 (entry up to Ø12 mm).

Alternatively, the feed box is fitted with a grommet (cable entry Ø20 - Ø75 mm).

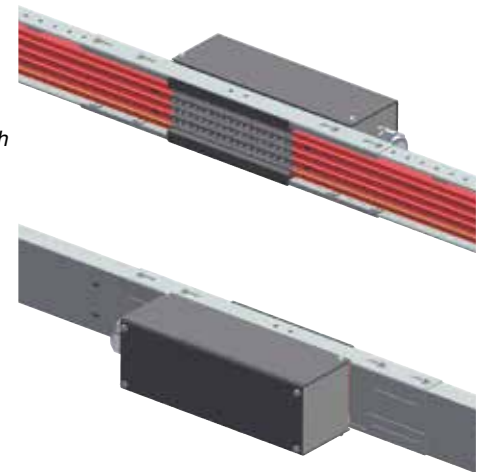

Line feed box with line feed clamp holder LCH

PR4-LB63

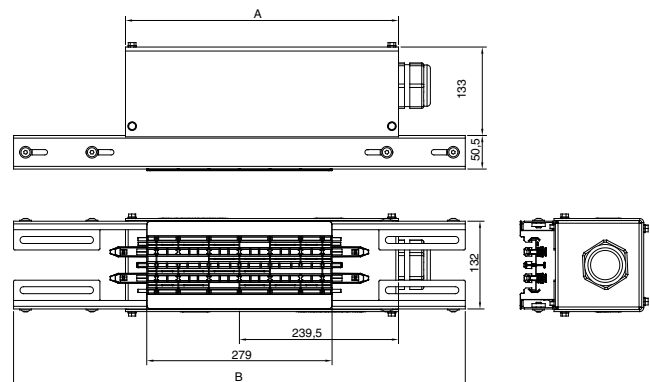

Dimensions A en B see table below

AKAPP ART. NO.	DESCRIPTION	TYPE	LENGTH FEED BOX A (mm)	LENGTH CS B (mm)
2040710	Line feed assembly	PR4-LBS40	309	680
2040715	Line feed assembly	PR4-LB63	411	680
2040720	Line feed assembly exp. rail	PR4-LB63-EXP-R	781	1395
2040725	Line feed assembly exp. rail+Cu	PR4-LB63-EXP-R-CU	1086	1395
2040728	Line feed assembly exp. rail+Cu+1xLCH	PR4-LB63-EXP-R-CU-1xLCH	582.3	1395
2040730	Line feed assembly with grommet	PR4-LBG	411	680
2040735	Line feed assembly with grommet exp. rail	PR4-LBG-EXP-R	781	1395
2040740	Line feed assembly with grommet exp. rail+Cu	PR4-LBG-EXP-R-CU	1086	1395
2040765	Line feed assembly with grommet exp. rail+Cu+1xLCH	PR4-LBG-EXP-R-CU-1xLCH	582.3	1395
2040575	Line feed clamp holder	PR4-LCH		

Feed boxes for PR7: practical and easy ways to connect!

There are several possibilities for connecting feed- and control cables to a Pro-Ductor installation.

The cables can either be connected to the end of the Pro-Ductor installation (end feed) or at a chosen point in the installation (line feed).

In most cases, a line feed can be applied as an end feed.

The **order** of the **copper channels** in the Pro-Ductor housing referring to the line feed clamp holders LCH and collector trolleys PCT can be viewed on the drawing on page 21.

When parallel mounting of the copper conductors is needed, e.g. to increase the maximum current capacity or to decrease the voltage drop, then you can use the line feed solutions as shown on pages 5 and 18.

Alternatively, you can use the Pro-Ductor PR10 system featuring 10 copper channels. It offers sufficient space for parallel mounted conductors for feed, combined with conductors for control functions.

See detailed information on page 17.

Feed boxes for Pro-Ductor PR7.

Line feed PR7-LB63/20 (normal connection):

Connects the feed cable (and/or control cable) to the end of, or at a chosen point in, a Pro-Ductor system (see picture beside). Fitted with cable glands M63 (cable entry up to $\text{Ø}44,5$ mm) and M20 (entry up to $\text{Ø}12$ mm).

Alternative: with grommet (cable entry $\text{Ø}20$ - $\text{Ø}75$ mm).

This feed box comes with a clamp holder (PR7-LCH), needed for mounting between two rail housing ends. In this clamp holder, the required feed clamps - to be ordered separately - are inserted.

The copper conductors can be connected easily and safely to the feed clamps. The copper conductors will not be interrupted! Also, a set connection strips (CS) to connect the steel support profile ends at both sides of the clamp holder is included.

Attention: all feed clamps and connectors are not included and must be ordered separately, depending on your copper configuration (see page 18).

Line feed PR7-LBS40/20 (normal connection):

As above, however with smaller cover and fitted with cable glands M40 (entry up to $\text{Ø}33$ mm) and M20 (entry up to $\text{Ø}12$ mm).

End feed box PR7-EK M40+M20 (on request)

Connects the feed cable (and/or control cable) to the end of a Pro-Ductor system (see picture next). Applicable up to copper conductors 125A.

The end feed box is supplied with cable glands M40 (entry up to $\text{Ø}33$ mm) and M20 (entry up to $\text{Ø}12$ mm). At the bottom 7 inserts M6 are provided for cable connection.

The recesses at the bottom of the feed box slide into the slots of the PR7 housing. The feed box is fixed with 2 joint pins (see picture). After connecting the wires of the feed cable to the copper conductors, the cover is placed.

Fixed point, type PR7-FP

The entire Pro-Ductor installation is to be fastened to the support profile by means of a fixed point set at the feed point or transfer side. This set contains 2 fixed point bolts with square nuts (see drawing). While screwing, the cone point of the bolt tightens itself into the PVC housing. From this point the PVC housing can slide freely into the support profile.

Line feed box with line feed clamp holder LCH (front view)

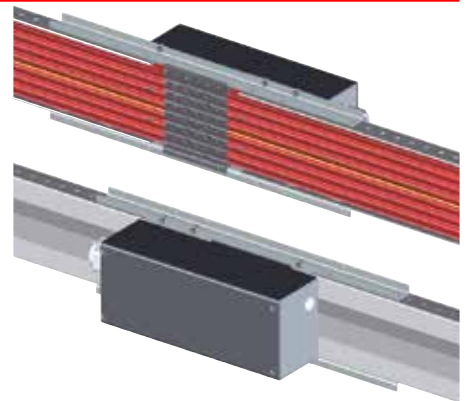

PR7-LB63/20

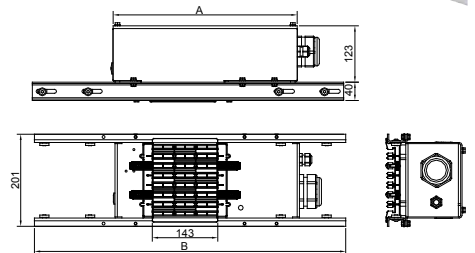

PR7-LBS40

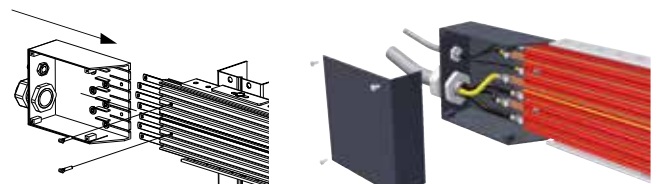
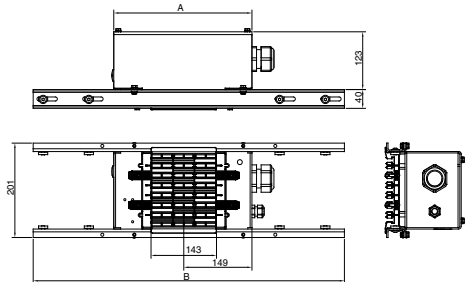

Mounting end feed box to PR7 housing)

End feed box

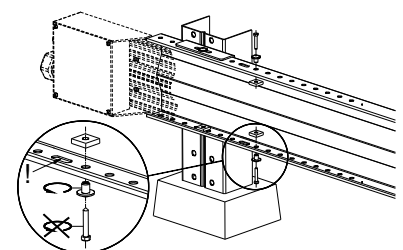

Fixation of housing PR7 with set PR7-FP

AKAPP ART.NO.	DESCRIPTION	TYPE	L FEED BOX A (mm)	L CS B (mm)
2001140	End feed box	PR7-EK M40+M20	200	-
2001590	Fixed point for PR7	PR7-FP		
2001900	Line feed with M63+M20	PR7-LB63/20	402	680
2001910	Line feed with grommet	PR7-LBG	402	680
2030330	Line feed assembly cmpl	PR7-LBS40/20	302	680
2030630	Line feed clamp holder	PR7-LCH		

Feed boxes for PR7: advanced solutions for parallel switching and expansion

The PR7 Pro-Ductor system offers the possibility to use parallel switched copper conductors. This is necessary for very high capacities up to 400A and/or decreasing of the voltage drop. The line feed clamp holder (LCH) can be fitted with a variety of line feed clamps and connectors in parallel settings. More on this, you can find on page 18.

When parallel mounting of the copper conductors should be combined with conductors for control functions, it can be necessary to use more than 7 copper channels. In these cases Pro-Ductor PR10, with 10 copper channels, is the ideal system.

See detailed information on page 17.

On this page, also the line feed boxes are listed for use in installations with expansion gaps or isolation sections. Within these line feeds, expansion of housing and/or copper conductors can be eliminated.

For alternative solutions, not listed here, please contact our sales office.

Feed boxes for Pro-Ductor PR7 (continued).

Line feed (parallel connection):

The same procedure as mentioned on page 11, however there are special clamp sets available for parallel mounting, fitting within the clamp holder. It enables connection of the connection cable simultaneously to 2 copper conductors.

The line feed comes with 1 connection core 50 mm² (see drawing) for the parallel connection of the both connectors next to the earth conductor.

Please note that all feed clamps and connectors are not included and must be ordered separately, depending on your copper configuration (see page 18).

The feed box is fitted with cable glands M63 (entry up to Ø44,5 mm) and M20 (entry up to Ø12 mm).

Alternatively, the feed box is fitted with a grommet (entry Ø20 - Ø75 mm).

Line feed (for housing expansion):

As mentioned above, however with extended cover, for a line feed clamp holder LCH and connection terminal.

These feed boxes are typically used for systems where the pvc housing is 'locked up' between 2 fixed points but the copper conductors are uninterrupted, e.g. when transfers are used.

Within this line feed box an expansion of the pvc housing of up to 376 mm is possible. The connecting cable is connected to the fixed terminal, while the flexible cores move with the housing and line feed clamp holder. For dimensions of the line feed box see drawing below.

The line feed box terminal is pre-wired, with 5 cores 50 mm² and 2 cores 6 mm² (see drawing).

Please note that all feed clamps and connectors are not included and must be ordered separately, depending on your copper configuration (see page 18).

The feed box is fitted with cable glands M63 (entry up to Ø44,5 mm) and M20 (entry up to Ø12 mm).

Alternatively, the feed box is fitted with a grommet (entry Ø20 - Ø75 mm).

Line feed (for housing and copper expansion):

These feed boxes are typically used for systems with expansion gaps or isolation sections. Please contact our sales office for further information on this.

Line feed box with 2 line feed clamp holders LCH (front view)

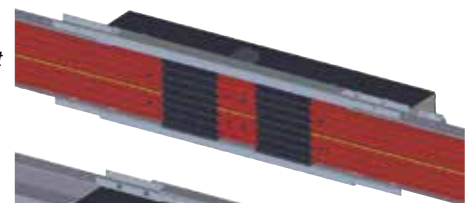

Line feed box (back view)



PR7-LB63/20-2xLCH

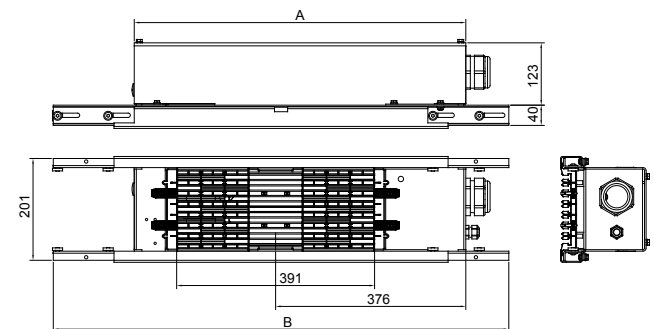

Line feed box for housing expansion with line feed clamp holder LCH (front view)

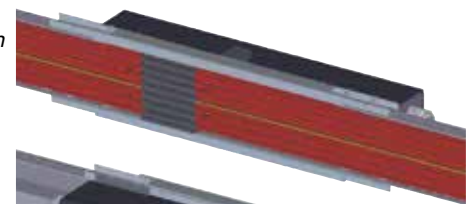

Line feed box for housing expansion (back view)

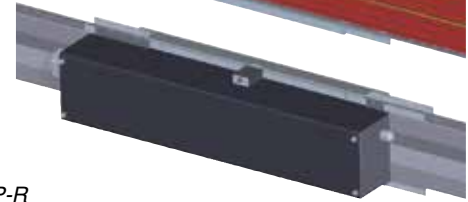

PR7-LB63/20-EXP-R

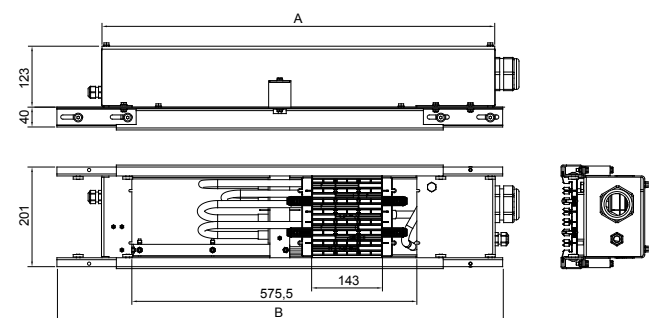

AKAPP ART.NO.	DESCRIPTION	TYPE	L FEED BOX A (mm)	L CS B (mm)
2001940	Line feed w. M63+M20, parallel	PR7-LB63/20-2xLCH	655	900
2001950	Line feed assembly compl.	PR7-LB63/20-EXP-R-CU-2xLCH	793	900
2001960	Line feed assembly compl.	PR7-LBG-EXP-R-CU-2xLCH	793	900
2030310	Line feed w. grommet, parallel	PR7-LBG-2xLCH	655	900
2001920	Line feed w. M63+M20, expans	PR7-LB63/20-EXP-R	793	900
2001930	Line feed w. grommet, expans	PR7-LBG-EXP-R	793	900

Feed boxes for PR10: easily connecting up to 400A!

For the connection of feed and control cables to an AKAPP Pro-Ductor system type PR10, two options exist: normal and parallel connection. Special connectors are available for parallel switching of copper conductors.

The feed box can be applied as end feed or as line feed; the cables can either be connected to the end of the Pro-Ductor installation (end feed) or at a chosen point in the installation (line feed).

Useful for increasing the maximum current or reducing the voltage drop.

The PR10 system offers sufficient space for parallel mounted conductors for feed, combined with conductors for control functions.

Line feed boxes can also be applied for installations with expansion gaps or isolation sections.

The **order** of the **copper channels** in the Pro-Ductor housing referring to the line feed clamp holders LCH and collector trolleys PCT can be viewed on the drawing on page 22.

Feed boxes for Pro-Ductor PR10.

Line feed (normal connection):

Connects the feed cable (and/or control cable) to the end of, or at a chosen point in, a Pro-Ductor system (see picture beside). The feed box is fitted with cable glands M63 (entry up to Ø44,5 mm) and M20 (entry up to Ø12 mm).

This feed box comes with a clamp holder (PR10-LCH), needed for mounting between two rail housing ends. In this clamp holder, the required feed clamps - to be ordered separately- are inserted.

The copper conductors can be connected easily and safely to the feed clamps. The copper conductors will not be interrupted! Also, a set connection strips (CS) to connect the steel support profile ends at both sides of the clamp holder is included.

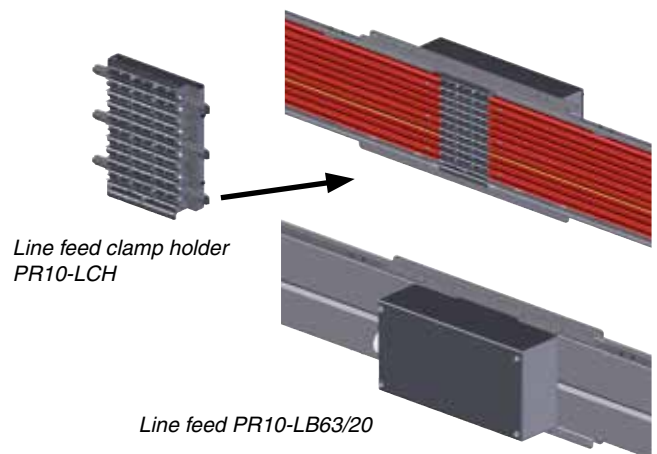

Line feed (parallel connection):

The same procedure as mentioned above, however there are special clamp sets available for parallel mounting, fitting within the clamp holder. It enables connection of the connection cable simultaneously to 2 copper conductors. More information on this you'll find on page 18.

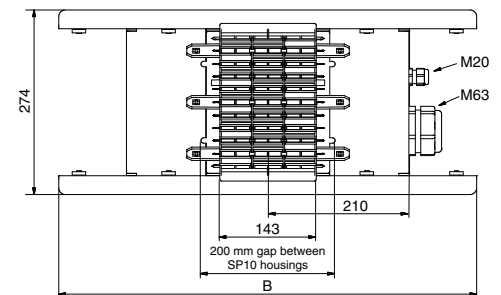
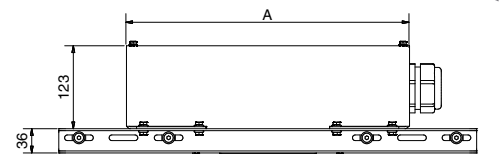

Line feed (extended performance):

As above, however with extended cover, for 2 pcs line feed clamp holders LCH. These feed boxes are typically used for systems with expansion gaps or isolation sections. The latter will split 2 current circuits from each other. For dimensions of the feed box see drawing below.

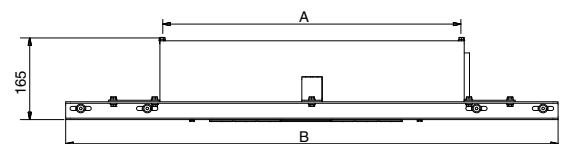

Dimensions of extended line feed PR10-EXP-CU

Special cable inlets on request.

AKAPP ART.NO.	DESCRIPTION	TYPE	L FEED BOX A (mm)	L CS B (mm)
2030700	Line feed assembly M63+M20	PR10-LB63/20	420	620
2030705	Line feed assembly f. expansion M63+M20	PR10-LB63/20-EXP	420	620
2030710	Line feed ass. extended cmpl M63+M20	PR10-LB63/20-2xLCH	662	987
2030715	Line feed ass. f. expansion M63+M20	PR10-LB63/20-EXP-R-CU	610	987
2030720	Line feed ass. f exp. w. grommet Ø20-75mm	PR10-LBG-EXP-R-CU	610	987
2030730	Line feed ass. extended cmpl w. grommet	PR10-LBG-2xLCH	662	987
2030530	Line feed clamp holder	PR10-LCH		

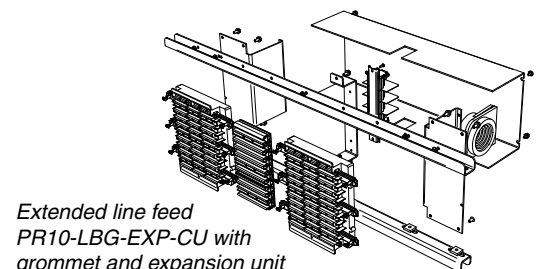

Connecting the copper conductors: skilful solutions with feed clamps

All line feed systems require clamp holders and feed clamps to connect the copper conductors within the rail housing to the cores of the supply cable.

There are 2 types of feed clamps: LC80 and LC200.

Feed clamps LC200 are used in combination with connectors. Copper conductors can be easily switched parallel or serial (coupled through). Even a combination is possible.

See details below.

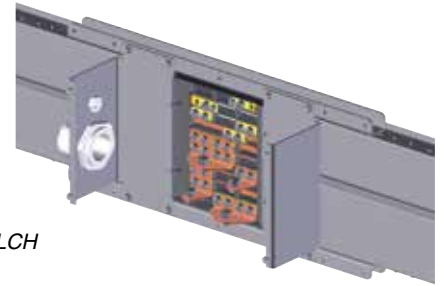

Clamp holder PR10-LCH with feed clamps

Feed clamps

Type LC80

Applicable for mounting of copper conductors CU35 - CU80.

Supplied without cable lug.

Type LC200

Applicable for mounting of copper conductors CU125 - CU200. A connector should be applied (to be ordered separately) to mount the cable lug.

Supplied without cable lug.

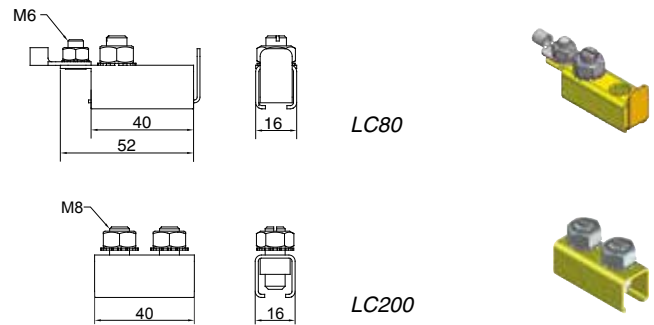

Connectors

Connectors are applied in combination with line feed clamps LC200. The connectors are supplied with a bolt M10, a nut and a washer to fix the cable lug (not supplied) of the feed cable.

There are 2 connector types:

Type C-LC.. for continuous copper conductors

Type CJ-LC.. for serial coupling of copper conductors

Connectors C(J)-LC400 are applied for parallel connecting of copper conductors in the line feed clamp holder LCH.

See the overview in the table below.

Connector	For feed clamp LC200	I _{max} (A)
Single row of feed clamps		
C-LC200	1 pc.	200
C-LC400	2 pc., parallel	400
Double row of feed clamps		
CJ-LC200	2 pc., serial	200
CJ-LC400	4 pc., 2 parallel + 2 serial	400

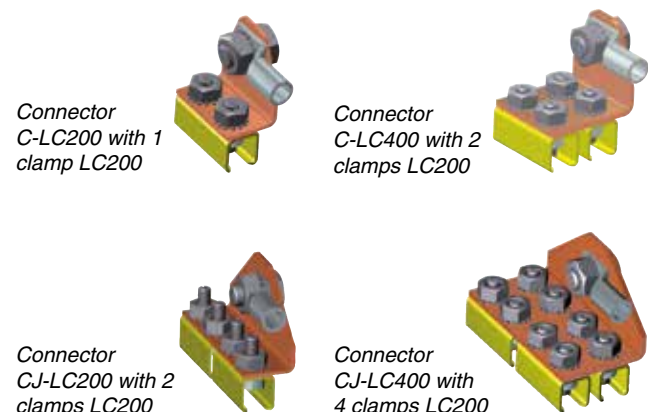
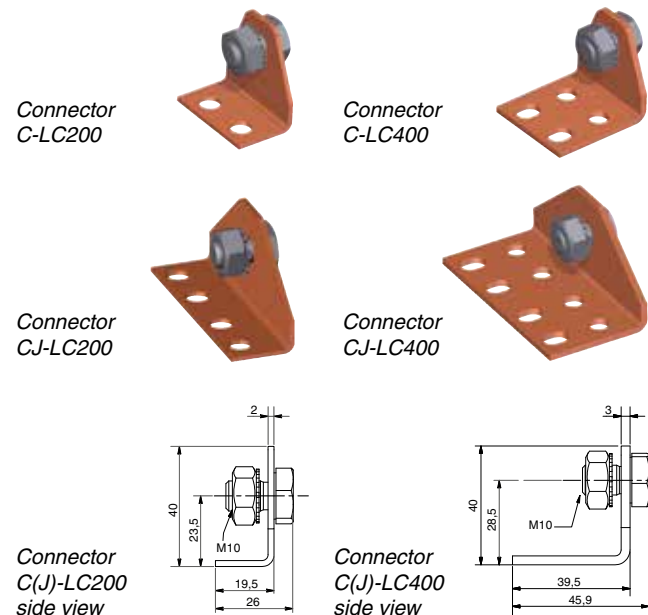

LINE FEED CLAMP AKAPP NO.	DESCRIPTION	QUANTITY	max. current (A) 80% D.C.
1012750	Feed clamp LC80	1 per conductor	80
1013000	Feed clamp LC200	1 per conductor	200

CONNECTOR AKAPP NO.	DESCRIPTION	QUANTITY	max. current (A) 80% D.C.
2030170	Connector C-LC200	1 per clamp	200
2030175	Connector C-LC400	1 per 2 clamps	400
2030180	Connector CJ-LC200	1 per 2 clamps	200
2030185	Connector CJ-LC400	1 per 4 clamps	400

Collector trolleys: designed for continuity!

The current conduction of the Pro-Ductor to the device to be fed is effected through the collector trolley. The contact with the **flat copper conductors** is maintained **uninterruptedly** by means of flexible, extreme wear-resistant carbon brushes manufactured from a specific bronze-carbon alloy.

The collector trolley is mounted to a special designed mounting bracket. This is fixed to the towing arm of the moving machine to be fed.

See also page 23.

The collector trolleys, with low wear ball beared synthetic wheels, combined with the uninterrupted copper conductors in the Pro-Ductor housing, enable **very high travel speeds**: standard up to **500 m/minute!**

The concept of all collector trolleys is based upon continuity: maximum reliability whilst minimum maintenance.

On page 24 and 25 you'll find information about collector trolleys for applications with aisle changing cranes.

Some important features:

Wheel guided collector trolley

The parabolic wheels and the unique four spring construction ensure correct guidance of the collector trolleys in the section grooves of the housing. This results in minimal wear of carbon brushes and p.v.c. railhousing and optimizes the electrical contact with the copper conductors.

Perfect signal transmission

As a result of the optimal correcting characteristics the carbon brushes always glide straight on the flat, smooth copper conductors. This ensures optimal feed and control. Furthermore, each brush is equipped with a compression spring (see picture below).

Quick installation

It is simple to mount the collector trolley to the mobile construction. The terminal box and the supporting profile both have the same height. This makes adjusting the collector trolley easy. Swinging of the warehouse crane during travelling is eliminated by the unique spring construction of the trolleys (horizontal 20 mm, vertical 10 mm deviation max.).

Steel terminal box

The trolley is fitted with a solid steel terminal box. Cables can be inserted from any side of the box. Standard with 2 cable glands; types PCT7: M40 and M20; types PCT10: M63 and M20. Furthermore there are blind covered holes in the other 3 sides of the box for mounting cable glands.

Suitable for curves, switches en transfers

The collector trolleys can, without any problem, travel within or outside the rail section. For instance, when the crane travels from one aisle to the next. In order to maintain an uninterrupted signal the two collector trolleys can be switched parallel. See also page 24 and 25.

Very low maintenance costs

The wheels and carbon brushes have minimum wear, since they are made of high quality, wear resistant, materials. This results in high reliability and performance, with minimal maintenance.

The construction of the collector trolley permits quick and easy replacement of the wheels and carbon brushes.

Other components do not require any maintenance.

AKAPP ART. NO.	DESCRIPTION	INDICATIVE LIFE CYCLE (KM) *)
2010811	Carbon brush PCT-P, phase	20.000
2010821	Carbon brush PCT-E, earth	20.000
2010831	Carbon brush PCT-PZ, silver graphite, phase	7.500
2010841	Carbon brush PCT-EZ, silver graphite, earth	7.500
2040630	Wheel PUR PCT4-W (for PCT4)	40.000
1512650	Wheel PUR PCT-W (for PCT7 / PCT10)	40.000
1449130.B0000	Torsion spring set left complete, for PCT	
1449140.B0000	Torsion spring set right complete, for PCT	

*) these values are without warranty

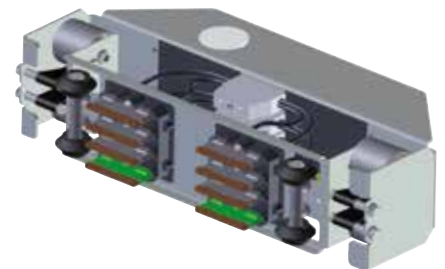

PCT4-4-125BI

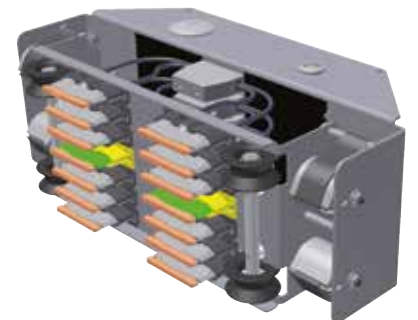

PCT7-7-125BI



PCT10-10-125BI-63-20

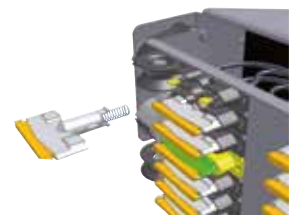

Replacing of carbon brushes is very easy

Inspection of the contact surface of the carbon brush

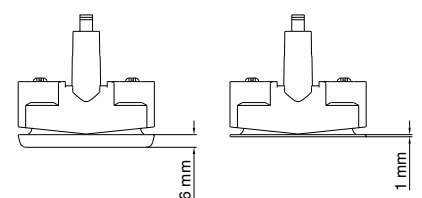

Collector trolleys series PCT4: combination of stability and reliability!

Pro-Ductor collector trolleys are available for range 3 to 4 conductors with nominal current carrying capacity up to **125A** (D.C. 80%).

Applicable from -30°C, which is especially important for deep freeze warehouses.

The collector trolleys are provided with terminals for cable cross sections from 4 mm² up to 25 mm².

The stable construction of the collector trolley, combined with the uninterrupted copper conductors enable very high travel speeds (standard up to 500 m per minute!).

There is a suitable trolley for each application. Not only for straight systems, but also for aisle changing cranes we offer you the best solution.

More information on this, you'll find on pages 24 and 25.

Collector trolleys series PCT4

Type PCT4...-125/BI

Current capacity up to 125A (80% I.D.). With double carbon brushes, internal wiring connected to a terminal. Integrated metal connection box, with cable glands M40 and M20.

Low-wear, ball-bearing parabolic wheels, perfectly guided in the section grooves of the housing. This prevents the brushes from touching the housing and so prevents wear of the housing and deposit of housing dust onto the copper conductors. Also, the wear of the carbon brushes and deposit of the carbon are reduced to the minimum.

Unique four spring construction, eliminating mechanical tolerances in horizontal and vertical movements during crane travel.

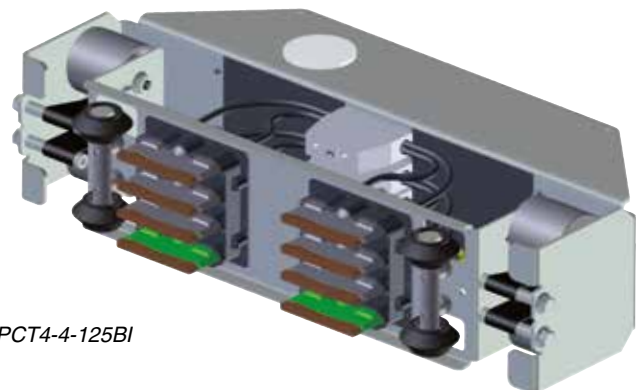

PCT4-4-125BI

Mounting bracket

Type PCT4-MB125

Galvanised steel, with mounting holes for mounting to a towing device of the movable machine. See also page 23.

Slots enable vertical adjustment of the trolley.

The dimensional sketch shows the most important dimensions and distances to calculate with when mounting a Pro-Ductor system.

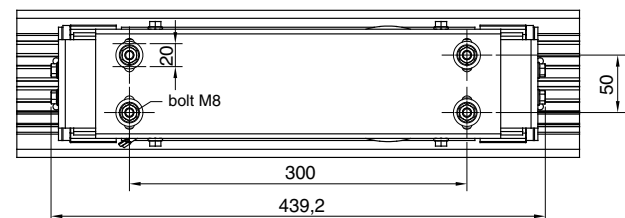
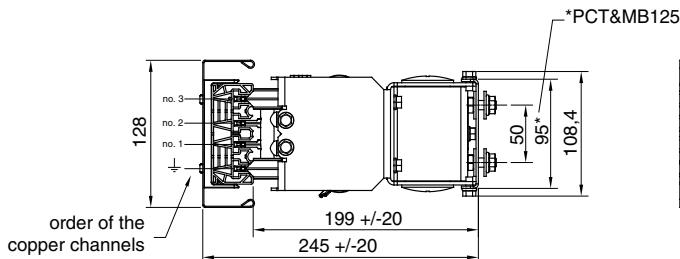
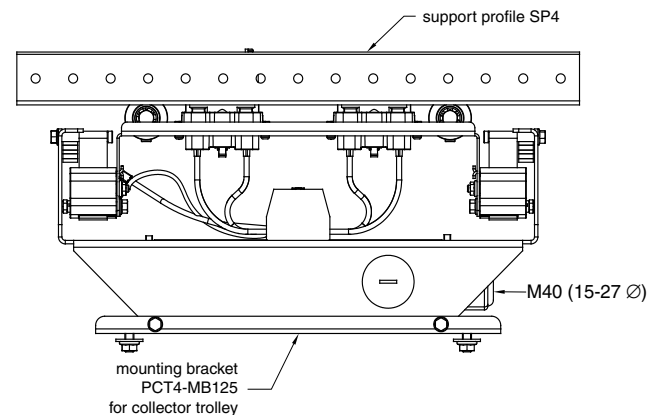

The drawing above shows the order of the copper conductors in the housing.

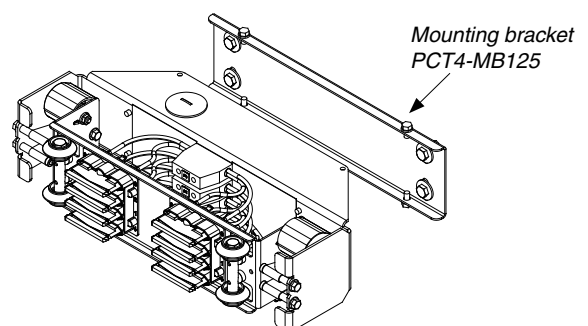

AKAPP ART. NO.	DESCRIPTION	TYPE
2040755	Collector trolley 4-pole 125A	PCT4-4-125/BI-40
2040750	Mounting bracket complete	PCT4-MB125

Collector trolleys series PCT7: combination of stability and reliability!

Pro-Ductor collector trolleys are available for range 4 to 7 conductors with nominal current carrying capacity up to **125A** (D.C. 80%).

Applicable from -30°C, which is especially important for deep freeze warehouses.

The collector trolleys are provided with terminals for cable cross sections from 4 mm² up to 25 mm².

The stable construction of the collector trolley, combined with the uninterrupted copper conductors enable very high travel speeds (standard up to 500 m per minute!).

There is a suitable trolley for each application. Not only for straight systems, but also for aisle changing cranes we offer you the best solution.

More information on this, you'll find on pages 24 and 25.

Collector trolleys series PCT7

Type PCT7-..-125/BI

Current capacity up to 125A (80% I.D.). With double carbon brushes, internal wiring connected to a terminal. Integrated metal connection box, with cable glands M40 and M20.

Low-wear, ball-bearing parabolic wheels, perfectly guided in the section grooves of the housing. This prevents the brushes from touching the housing and so prevents wear of the housing and deposit of housing dust onto the copper conductors. Also, the wear of the carbon brushes and deposit of the carbon are reduced to the minimum.

Unique four spring construction, eliminating mechanical tolerances in horizontal and vertical movements during crane travel.

An overview of available trolley types is listed in the table below.

Mounting bracket

Type PCT7-MB125

Galvanised steel, with mounting holes for mounting to a towing device of the movable machine. See also page 23. Slots enable vertical adjustment of the trolley.

The dimensional sketch shows the most important dimensions and distances to calculate with when mounting a Pro-Ductor system.

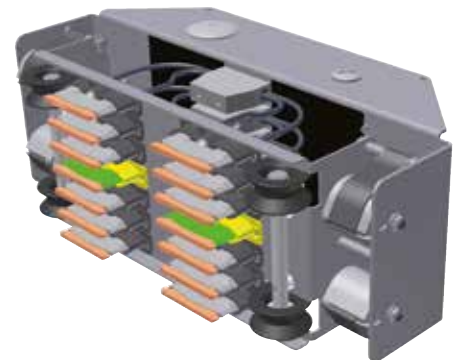

PCT7-7-125BI

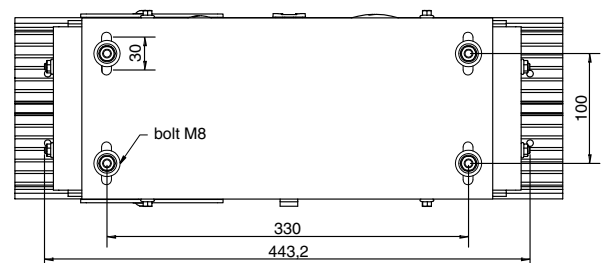
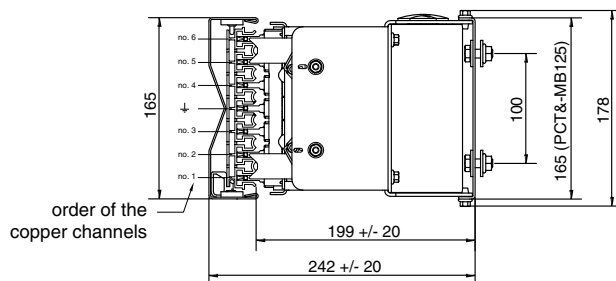
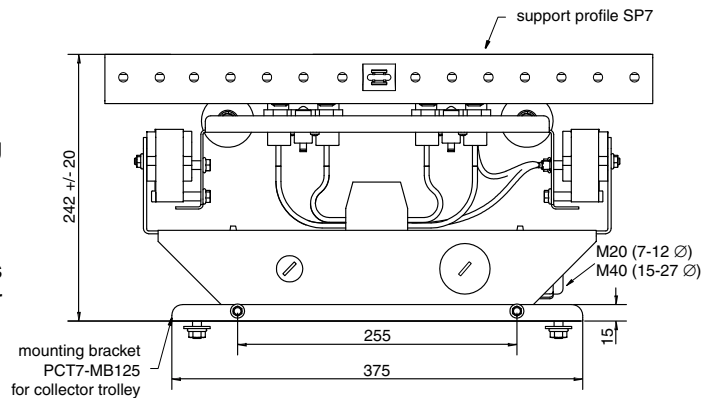

Mounting bracket
PCT7-MB125

The drawing above shows the order of the copper conductors in the housing.

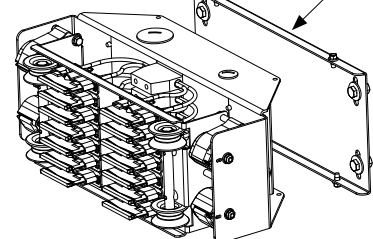

AKAPP ART. NO.	DESCRIPTION	TYPE
2012360	Collector trolley 4-pole 125A	PCT7-4-125/BI
2012370	Collector trolley 5-pole 125A	PCT7-5-125/BI
2012380	Collector trolley 6-pole 125A	PCT7-6-125/BI
2012350	Collector trolley 7-pole 125A	PCT7-7-125/BI
2010270	Mounting bracket incl. fastening materials	PCT7-MB125

Collector trolleys series PCT10: combine high currents with control functions!

Pro-Ductor collector trolleys PCT10 are available for range 5 to 10 conductors with nominal current carrying capacity up to **125A** (D.C. 80%) or up to 250A with parallel switched carbon brushes.

Applicable from -30°C, which is especially important for deep freeze warehouses.

The collector trolleys are provided with terminals for cable cross sections from 4 mm² up to 25 mm².

The stable construction of the collector trolley, combined with the uninterrupted copper conductors enable very high travel speeds (standard up to 500 m per minute!).

Combining high current capacities with control functions is very easy with AKAPP Pro-Ductor PR10, that offers up to 400A nominal current! Of course, the collector trolley series PCT10 offer the perfect match to this system.

Read more below.

Collector trolleys series PCT10

Type PCT10-...-125/BI

Current capacity up to 125A (80% I.D.). With double carbon brushes, internal wiring connected to a terminal. Integrated metal connection box, with cable glands M63 and M20.

Low-wear, ball-bearing parabolic wheels, perfectly guided in the section grooves of the housing. This prevents the brushes from touching the housing and so prevents wear of the housing and deposit of housing dust onto the copper conductors. Also, the wear of the carbon brushes and deposit of the carbon are reduced to the minimum.

Unique four spring construction, eliminating mechanical tolerances in horizontal and vertical movements during crane travel.

An overview of available trolley types is listed in the table below.

Mounting bracket

Type PCT10-MB125

Galvanised steel, with mounting holes for mounting to a towing device of the movable machine. See also page 23.

Slots enable vertical adjustment of the trolley.

The dimensional sketch shows the most important dimensions and distances to calculate with when mounting a Pro-Ductor system.

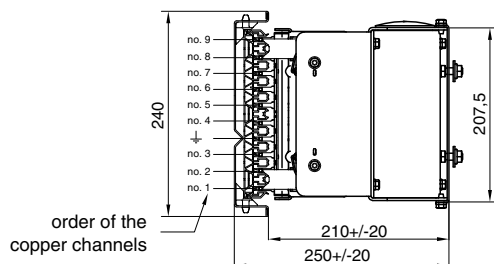

PCT10-10-125BI-63-20

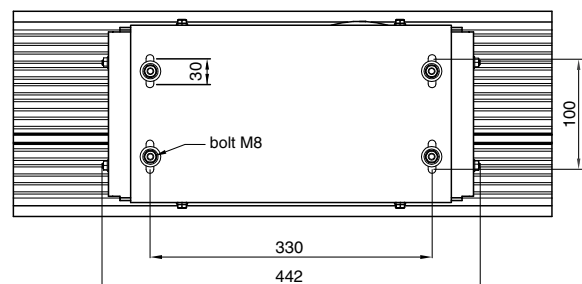
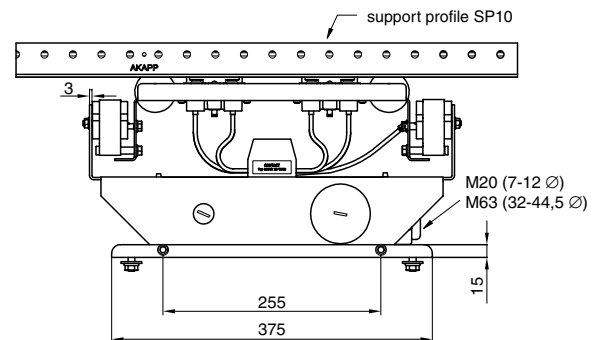

The drawing above shows the order of the copper conductors in the housing.

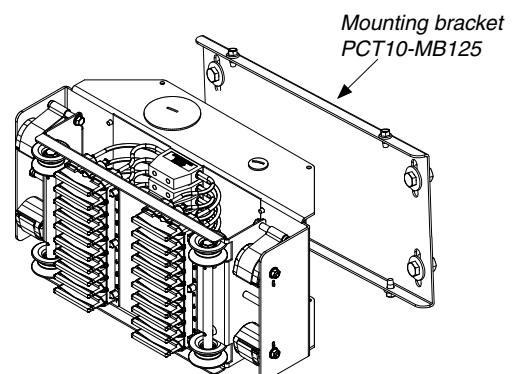

AKAPP ART. NO.	DESCRIPTION	TYPE
2031100	Collector trolley 10-pole 125A	PCT10-10-125/BI-63/20
2031105	Collector trolley 9-pole 125A	PCT10-9-125/BI-63/20
2031110	Collector trolley 8-pole 125A	PCT10-8-125/BI-63/20
2031120	Collector trolley 6-pole 125A	PCT10-6-125/BI-63/20
2030555	Brush guide	PCT10-G
2030166	Mounting bracket incl. fastening materials	PCT10-MB125

More on collector trolleys:

leading edge design; optimal performance!

When developing the collector trolleys, reliability and durability were the most important issues.

The leading edge design, combined with the high quality components, form the basis for outstanding trolley performance.

Mounting and adjusting of the trolleys is very quick and easy.

The solid construction and easy alignment of the collector trolleys contribute to the extremely low wear, with optimal performance!

Mounting of the collector trolley

The collector trolleys PCT7 and PCT10 are easily mounted to the moving apparatus using a mounting bracket (ordered separately). See picture.

The glands for the connection cables can be mounted on any of the sides of the steel terminal box by removing the appropriate blank hole.

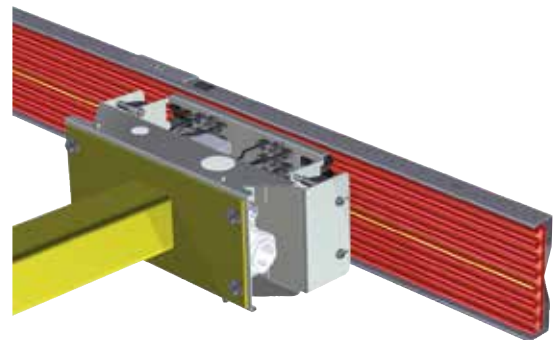

Collector trolley, mounted on the towing arm

After fixing of the mounting bracket, the trolley needs to be aligned.

Horizontal alignment

It is very important that the carbon brushes maintain the proper spring force when determining the exact length of the towing arm. See pictures to check the distances between towing arm end and the mounting bracket. A tolerance of 20 mm is permitted.

Mounting of trolley PCT4-x-125 on towing arm

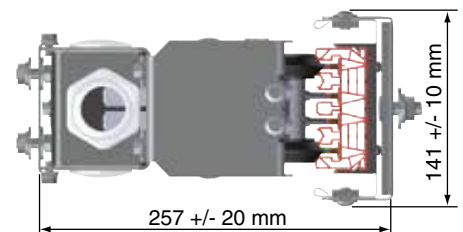

Vertical alignment

The height of the mounting bracket and the steel support profile are the same. This makes vertical alignment easy, e.g. by means of a level. A tolerance of 10 mm is permitted.

Mounting of trolley PCT7-x-125 on towing arm

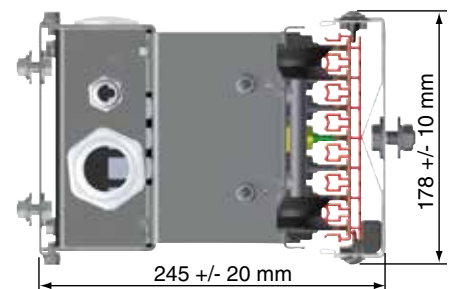

After alignment of the mounting bracket, the collector trolley can be mounted to it. Finally, the appropriate cables can be connected to the terminals.

Special collector trolleys

There are special types available for aisle changing cranes, which demand the use of transfer guides. See page 24 and 25 for more information about these applications.

Mounting of trolley PCT10-x-125 on towing arm

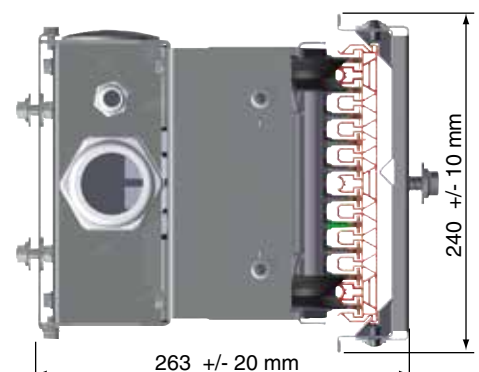

Special applications with Pro-Ductor®:

aisle-changing cranes

AKAPP Pro-Ductor system is extremely flexible and versatile because of the unique design.

It offers solutions for feeding problems in numerous applications, in a wide variety of circumstances.

Pro-Ductor systems can be applied for **aisle changing** (warehouse) cranes, where the crane moves from the main aisle into one or more side corridors. These applications require transfer guides.

In the main aisle one or more straight transfer guides are located. At the end of each side corridor there are curved transfer guides (left or right curves). A bend can also be realised by a curved housing section PR7.

Aisle changing cranes are provided with 2 collector trolleys. A special guide construction on these collector trolleys enables smooth and trouble free operation.

For more information on collector trolleys, see page 25.

Aisle-changers for Pro-Ductor (PR7/PR10).

Transfer guide sections

At the end of each aisle is a curved transfer guide, while in the main aisle straight transfer guides must be installed. These transfer guides are needed to lead the collector trolleys smoothly into the other track.

The crane can approach transfer sections from both sides, so the travelling direction is not relevant.

The travelling speed at the transfer guide may not exceed 80 m/minute.

Transferguide sections PRx-TGC are supplied with a **special mounting bracket**, with 2 holes for bolts M10 located just above and below the level of the support profile SP7/SP10, that enables vertical adjustment of the support profile even after the p.v.c. housing PR7 or PR10 is mounted.

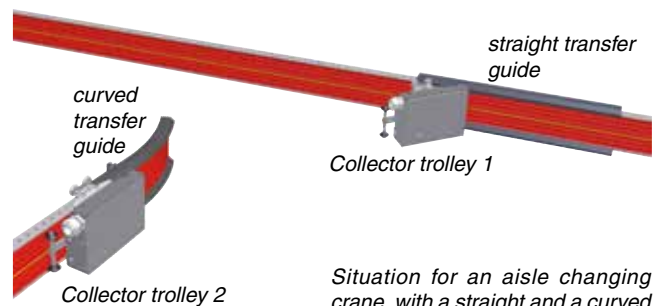

Situation for an aisle changing crane, with a straight and a curved transfer guide, plus 2 special collector trolleys.

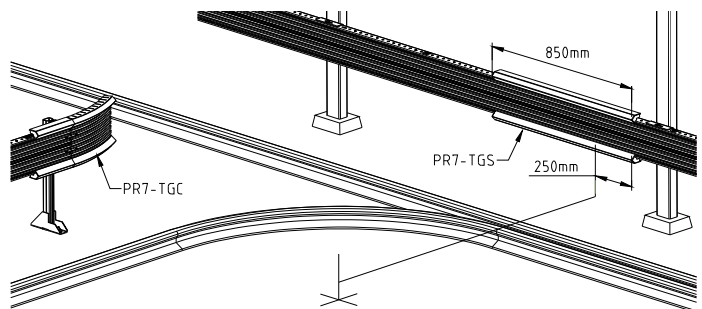

Mounting bracket for support post, type SPx-MB/P

This special mounting bracket is used in combination with SP7-P support posts. In contrast to the standard SPx-MB it can be adjusted after the SP7 or SP10 support profile is mounted by means of 2 holes for bolts M10, just above and below the level of the support profile.

Therefore it is used as the last bracket at the end of aisles with transfer guides for optimal adjustment of the transfer guide section. See drawing next.

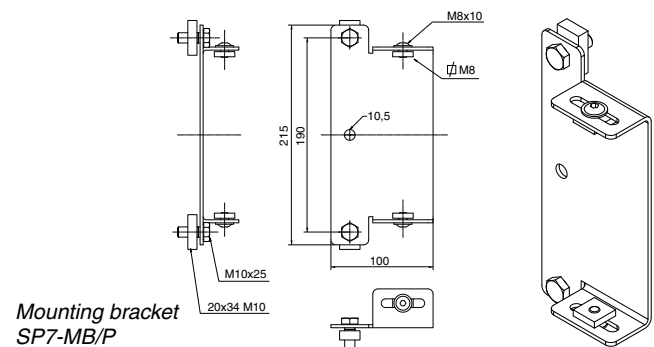

Mounting bracket SP7-MB/P

AKAPP ART.NO.	DESCRIPTION	TYPE
2005020.B0000	Transfer guide curved, right	PR7-TGC-R
2005020.B0001	Transfer guide curved f. expansion, right	PR7-TGC-EXP-R
2005020.B0002	Transfer guide curved f. expansion, left	PR7-TGC-EXP-L
2005020.B0003	Transfer guide curved, left	PR7-TGC-L
2005000.B0000	Set Transfer guide straight, incl. fasteners	PR7-TGS
2019412	Mounting bracket for support post complete	SP7-MB/P
2007010.B0000	Transfer guide curved, right	PR10-TCG-R
2007020.B0000	Transfer guide curved f. expansion, left	PR10-TCG-L
2007040.B0000	Set Transfer guide straight, incl. fasteners	PR10-TGS
2030425	Mounting bracket for support post complete	SP10-MB/P

Guide construction on collector trolley for smooth operation at transfer guides

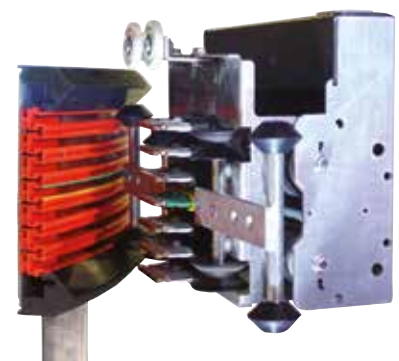

Special applications with Pro-Ductor®:

collector trolleys for aisle changing cranes

Collector trolleys for aisle changing cranes are provided with a special guide construction for smooth and trouble free movement through the transfer guides. On page 18 the principle of a transfer is shown.

A bend section can also consist of a **curved Pro-Ductor housing**. The radius of the housing should be between 1200 and 4000 mm.

In that case, the carbon brushes of the collector trolley will remain contact with the copper conductors.

This requires special prepared collector trolleys. These types are listed in the table below.

Standard the collector trolleys feature a terminal box with cable gland M40 for the cable entry. Terminal connectors for cables up to 10 mm².

You'll find an overview of standard available collector trolleys in the tabel below.

Alternative performances on request.

Collector trolleys for aisle changing cranes

Collector trolleys type PCT7-.-63/CA/..

Capacity up to 63A (80% I.D.) per collector trolley. Available in 4, 5, 6 or 7-pole performance.

An aisle changing crane must be fitted with 2 collector trolleys, using a special guide construction. These trolleys are parallel mounted to prevent interruption of the current while the crane is changing from aisle.

Mounting set PCT-SB for PCT7-.-63/CA/..

This set contains 2 steel brackets, mounted on both sides of the trolley, which enables the trolley to be mounted to the towing construction of the moving apparatus to be fed.

Sensor bracket PCT63 for PCT7-.-63/CA/..

Brackets can be positioned on the wheel assembly of the PCT63, enabling placement of an inductive sensor (Ø18 mm). This sensor signal can be used to switch on/off of the PCT when changing aisle. Sensor not included.

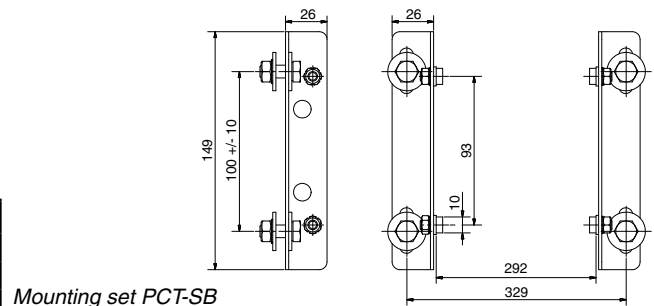
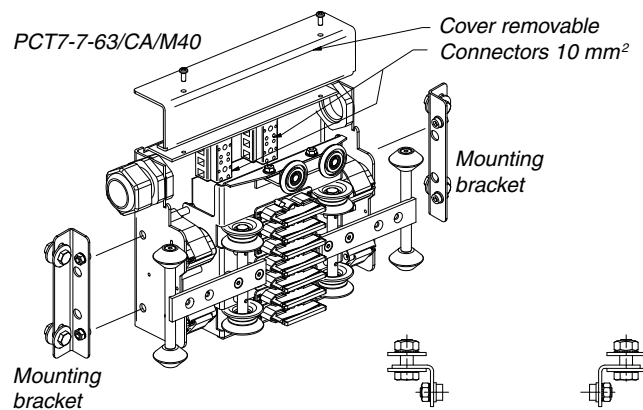

Mounting set PCT-SB

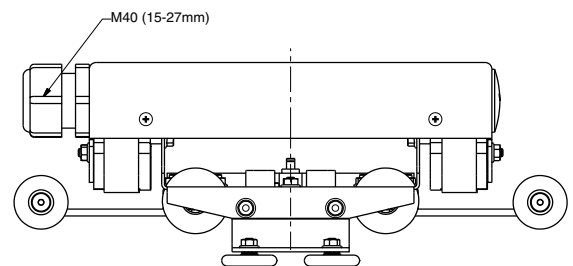

AKAPP ART.NO.	DESCRIPTION	TYPE
2012345.B0002	Collector trolley 4-pole 63A with cable gland M40	PCT7-4-63/CA/M40
2012345.B0001	Collector trolley 5-pole 63A with cable gland M40	PCT7-5-63/CA/M40
2012345.B0005	Collector trolley 6-pole 63A with cable gland M40	PCT7-6-63/CA/M40
2012345.B0000	Collector trolley 7-pole 63A with cable gland M40	PCT7-7-63/CA/M40
Collector trolleys for curved sections PR7 (radius 1200 - 4000 mm)		
2012345.B0004	Collector trolley 4-pole 63A with cable gland M40 for curves	PCT7-4-63/CA/M40
2012345.B0003	Collector trolley 6-pole 63A with cable gland M40 for curves	PCT7-6-63/CA/M40
Accessories for above mentioned collector trolleys		
2012400	Mounting set PCT-SB	PCT-SB
2009318	Mounting bracket for 18mm induction sensor	PCT63

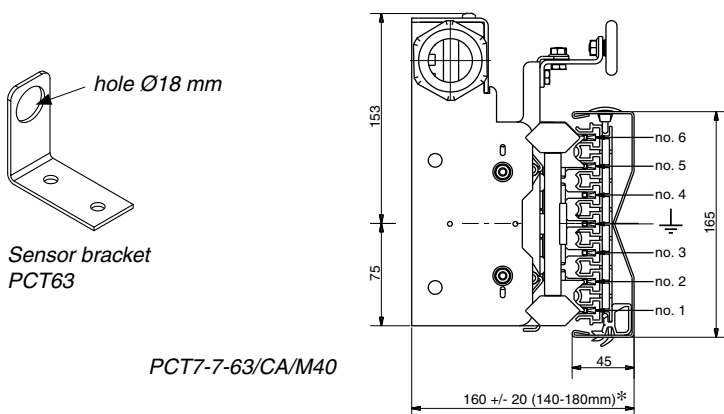

Sensor bracket PCT63

PCT7-7-63/CA/M40

* Attention: Reduced tolerance when using sensor bracket!

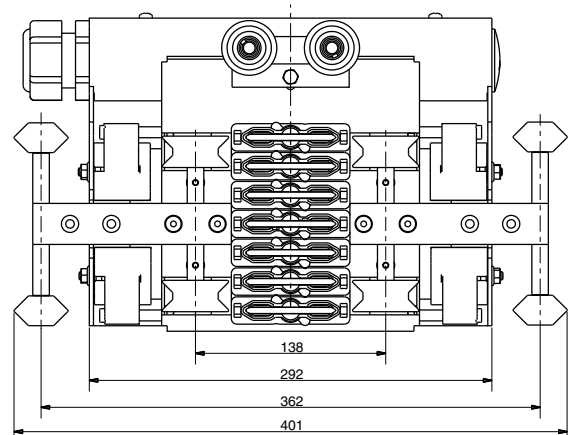

Special applications with Pro-Ductor®:

‘Mast conductor bar’, vertical system on warehouse cranes

AKAPP Pro-Ductor PR7 can be mounted vertically to the mast of a warehouse crane for the feeding and/or control of the control unit. Within the Pro-Ductor type PR7 housing, up to 7 copper conductors can be applied according to the specific demands of the control unit. This system can be applied without support profile.

Above this, the system can optionally be fitted with a code rail, which offers exact positioning of the crane control unit while moving up- and downwards.

For this application, a special designed self-aligning collector trolley featuring double carbon brushes per conductor offers a trouble free transfer of power and control signals.

The most important advantages of this ‘Mast conductor bar’ application are e.g. the very compact performance, easy installing, flexibility of applied copper conductors, low maintenance and very high dependability.

Details for PR4 and PR10 systems on request.

Components of a Mast conductor bar system (see also the system lay out on page 27)

Rail housing PR7

The rail housing can be mounted to the mast of a warehouse crane up to a length of 30 metres, which means that it can be used on large warehouse cranes and on mini loads.

The rail housing is fitted by means of mounting brackets type PR7-MB (see drawing). For free expansion of the housing, it glides into these mounting brackets.

Feed box PR7-EBS

At the bottom of the system the feed box PR7-EBS is mounted to the mounting bracket type PR7-MP (see drawing). From this point the pvc housing can expand and shrink freely if the ambient temperature changes. The feed box is provided with 7 glands M16, for the connection of the feed cables to the copper conductors. This feed box is applicable for use with 50A and 80A conductors. Because of expansion issue, the conductors will be fixed at the top of the system (see under ‘End cap’).

End cap PR7-EC

The end cap encloses the system on top. The copper conductors are mounted in ‘hanging position’, using the provided brass screw connecting clamps at the top of the rail housing. See drawing next.

Collector trolley PCT7-7-70/NT

The collector trolley PCT7-7-70/NT has been designed especially for this application. It is featured with a double carbon brushes (2x35A) for each conductor and with self-aligning wheels. The spring system ensures that the trolley follows the movements of the crane control unit perfectly, eliminating horizontal and vertical tolerances and preventing the carbon brushes to affect the pvc housing. The collector trolley is provided with 7 glands M16, for putting out the connection cables to the crane unit. See drawing.

Code rails

In combination with the housing PR7, code rails can be applied (see also page 28), which offers very precise vertical positioning of the control unit.

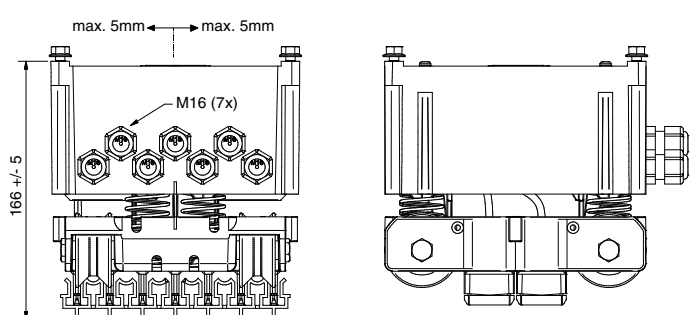
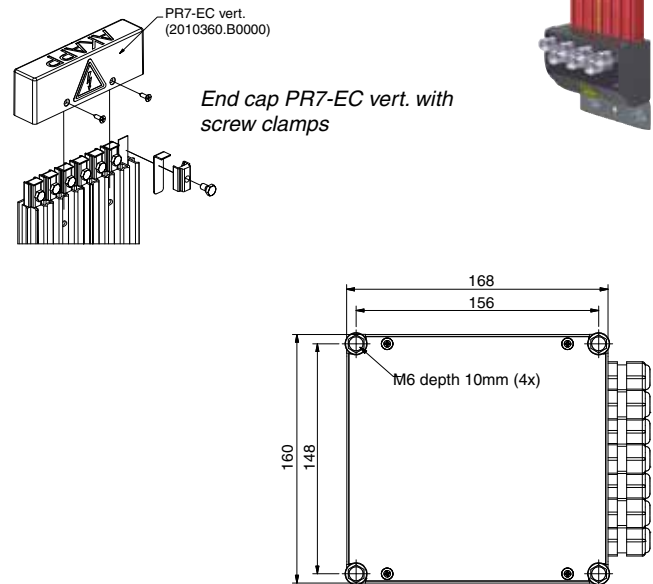
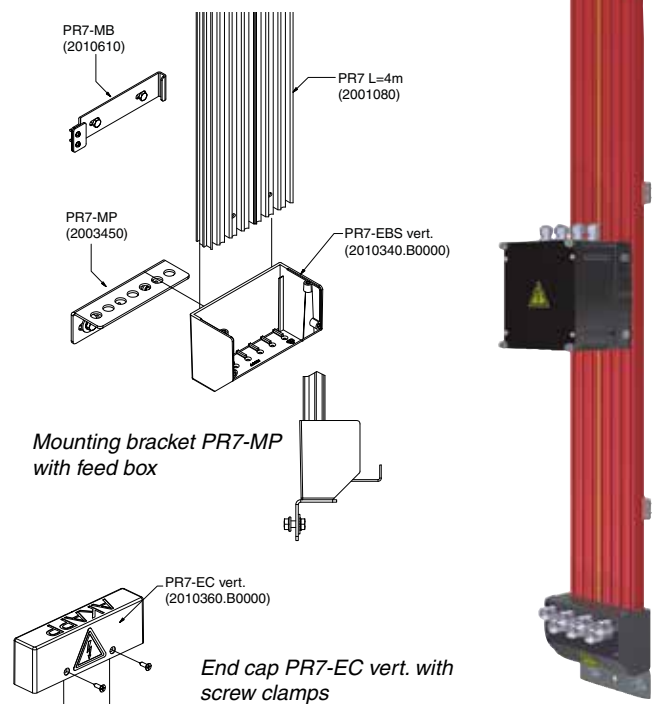

Collector trolley PCT7-7-70/NT

Configuration 'Mast conductor bar' system: Pro-Ductor in vertical application

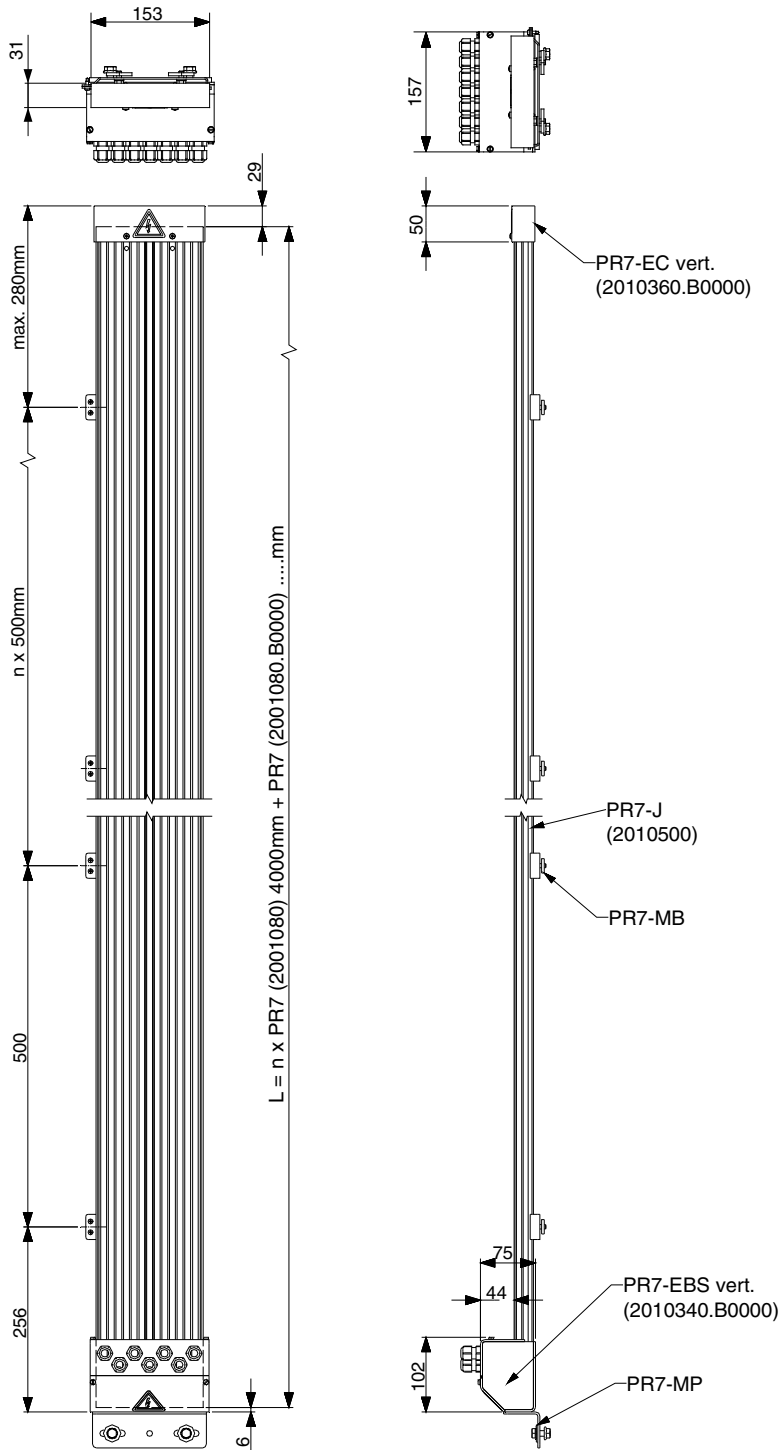

Mast conductor bar application (7-pole Pro-Ductor system) on mini-load

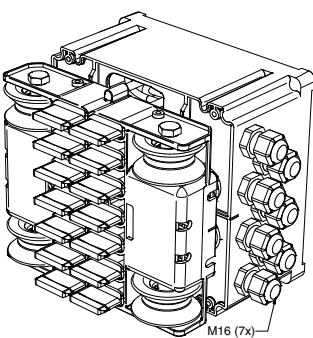

AKAPP ART.NO.	DESCRIPTION	TYPE
2001080	PVC housing, red	PR7
2003450	Mounting bracket bottom	PR7-MP
2010340.B0000	End feed box vertical-below, expansion	PR7-EBS
2010610	Mounting bracket	PR7-MB-S
2010500	Set for PR7 joint	PR7-J
2010360.B0000	End cap for vertical-top	PR7-EC
2012370.B0000	Collector trolley 70A for PR7 vertical	PCT7-7-70/NT/16-7

Special applications with Pro-Ductor®: positioning systems

AKAPP Pro-Ductor systems can be used in combination with electronic control systems, such as PROFIBUS®.

Advanced methods of positioning (e.g. with barcode) are also possible. The support profile can be extended with a special barcode strip.

Below are some examples.

For further information please contact our head office. The addresses are listed on the front cover of this brochure.

Positioning systems for Pro-Ductor.

Barcode tape BCB

A metal strip provided with barcode tape is mounted on the top or below the support profile SP4, SP7 or SP10. This strip, made of spring steel, is mounted between 2 tensioners, to maintain the straight shape of the strip. This is very important because of the accurate reading of the barcode.

The reader fitted on the (warehouse) crane reads the barcode while the crane moves and determines the crane position relative to the barcode tape.

Depending on the operating system, this information can be sent through the Pro-Ductor system to a processor for further use with additional software.

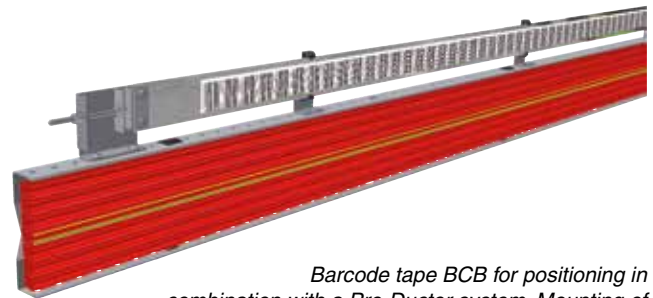

Barcode tape BCB for positioning in combination with a Pro-Ductor system. Mounting of the tape at the bottom of the support profile is also possible.

Code rail WCS3

On the top or at the bottom of the support profiles SP4, SP7 and SP10 a special punched code rail can be mounted. On the (warehouse-)crane an optical device is mounted, that reads the punched code while the crane moves and accurately determines the position of the crane.

Depending on the operating system, this information can be sent through the Pro-Ductor system to a processor for further use with additional software.

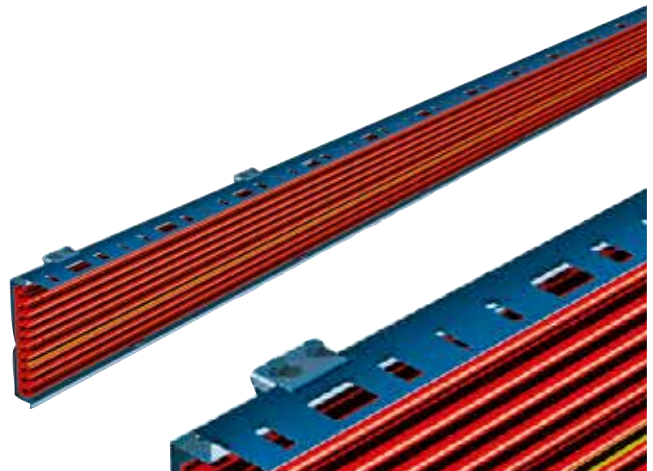

Code tape WCS3 for positioning in combination with a Pro-Ductor system. Mounting of the tape at the bottom of the support profile is also possible.

Please contact our sales office for further information on this and other positioning systems that can be combined with AKAPP Pro-Ductor.

AKAPP ART. NO.	DESCRIPTION	TYPE
Barcode rail system BCB		
2001340.B0000	Tensioner for BCB-S complete	BCB-T
2001350	Bracket for barcodeband BCB-H	BCB-H
2001325.B0000	BCB-S Bar Code on steel strip H=50mm	BCB-S
Code rail system WCS3		
2010700	Clamp set for SP7	SP7-WCS3
2010900	Clamp set for SP10	SP10-WCS3
2095020.B0000	Coderail without mounting holes	WCS3-CS70-L0
2095020.B0005	Coderail stainless steel without mounting holes	WCS3-CS70-M1



Application of a 10-pole Pro-Ductor system with code rail

Configuration Pro-Ductor PR4 systems: some important remarks

Pro-Ductor systems offer a high level of mounting flexibility. You can determine the most suitable location of the feed point (end- or line feed), considering the local situation and volt drop.

The minimum mounting height is 160 mm (top PCT4).

The graphics below show the typical configuration options for PR4 systems, with and without support profile SP4.

LEGENDE:

- | | |
|--|--|
| 1. Housing PR4 | 7. Joint for housing |
| 2. Support profile SP4 | 8. End cap |
| 3. Mounting bracket f. support profile | 9. Support |
| 4. Joint for support profile | 10. Collector trolley |
| 5. Feed box | 11. Mounting bracket for collector trolley |
| 6. Mounting clip for housing | |

- ① **System**
type PR4 +SP4
Line feed as
End feed

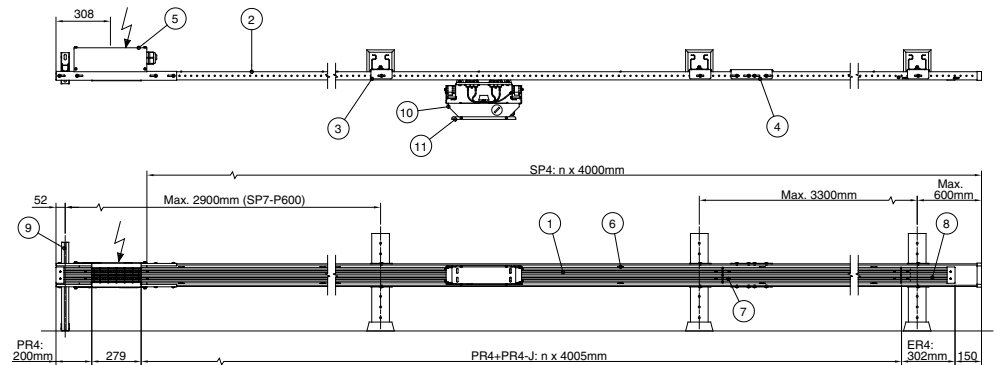

- ② **System**
type PR4 +SP4
Line feed

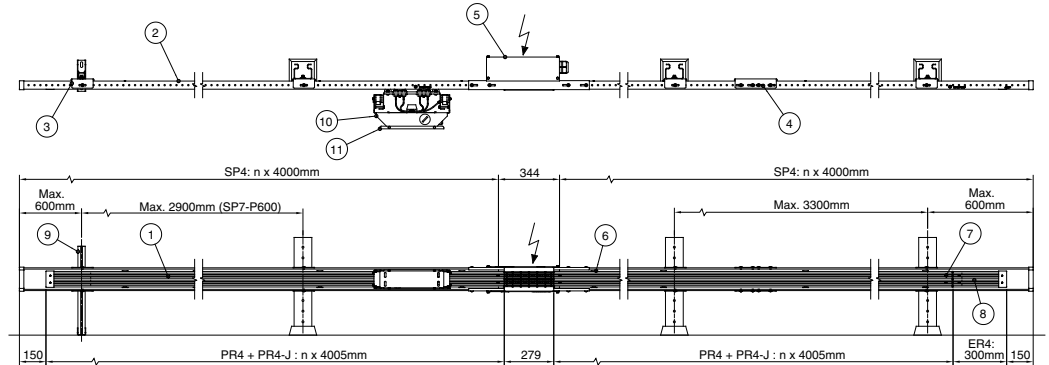

- ③ **System**
type PR4
Without SP4
Line feed as
End feed

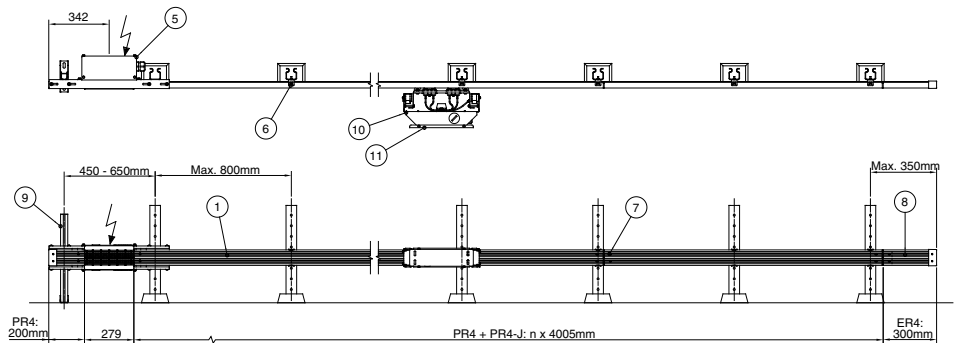

- ④ **System**
type PR4
Without SP4
Line feed

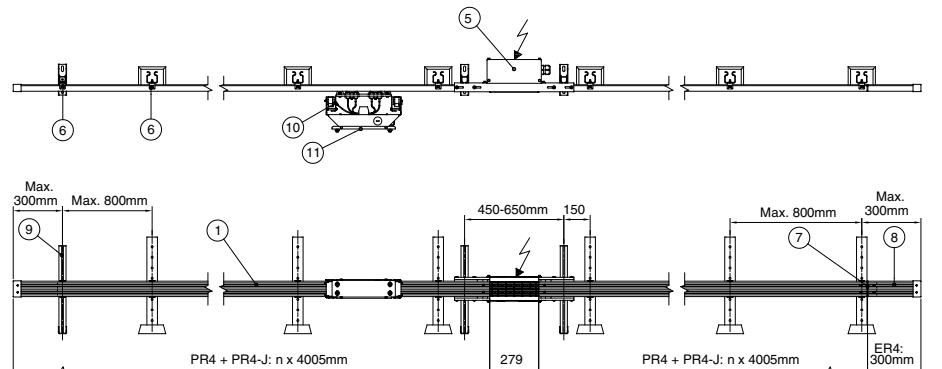

Configuration Pro-Ductor PR7/PR10 systems: some important remarks

Pro-Ductor systems offer a high level of mounting flexibility. You can determine the most suitable location of the feed point (end- or line feed), considering the local situation and volt drop.

The minimum mounting height is 200 mm (top PCT7 and 275 mm (top PCT10).

The graphics below show the typical configuration options for PR7 and PR10 systems, complete with support profile SP7 and SP10.

LEGENDE:

- | | |
|--|--|
| 1. Housing PR7/PR10 | 7. Joint for housing |
| 2. Support profile SP7/SP10 | 8. End cap |
| 3. Mounting bracket f. support profile | 9. Support |
| 4. Joint for support profile | 10. Collector trolley |
| 5. Feed box | 11. Mounting bracket for collector trolley |
| 6. Mounting clip for housing | |

① **System**
type PR7
Line feed as
End feed

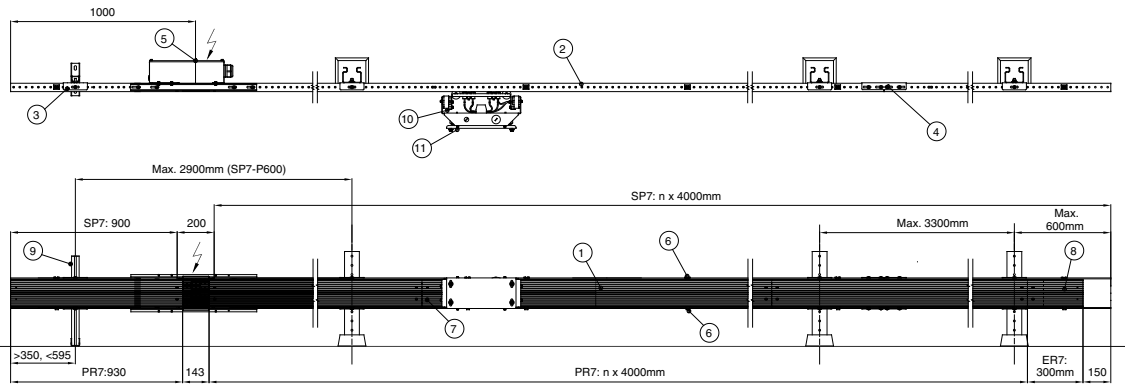

② **System**
type PR7
Line feed

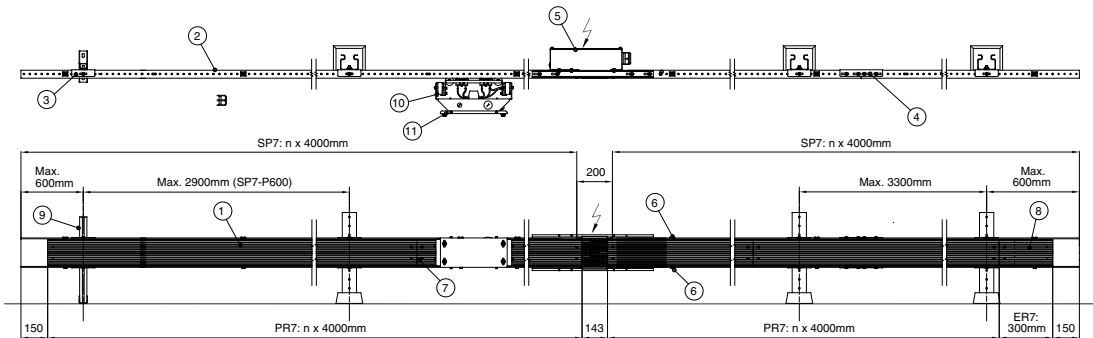

③ **System**
type PR10
Line feed as
End feed

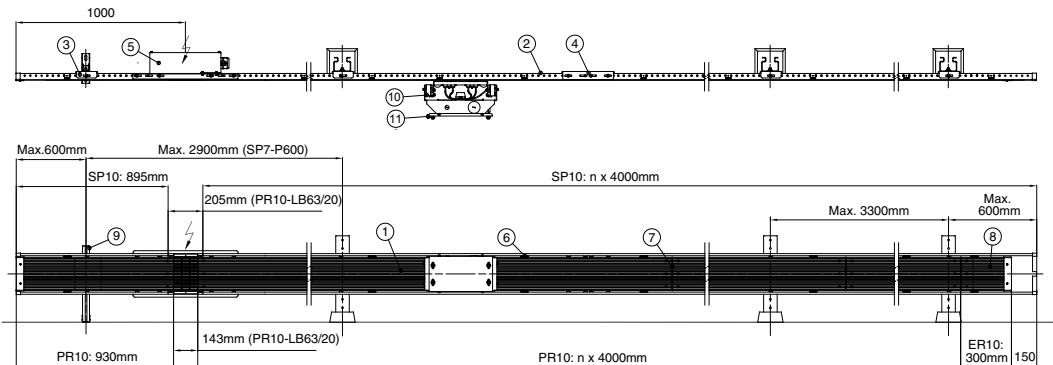

④ **System**
type PR10
Line feed

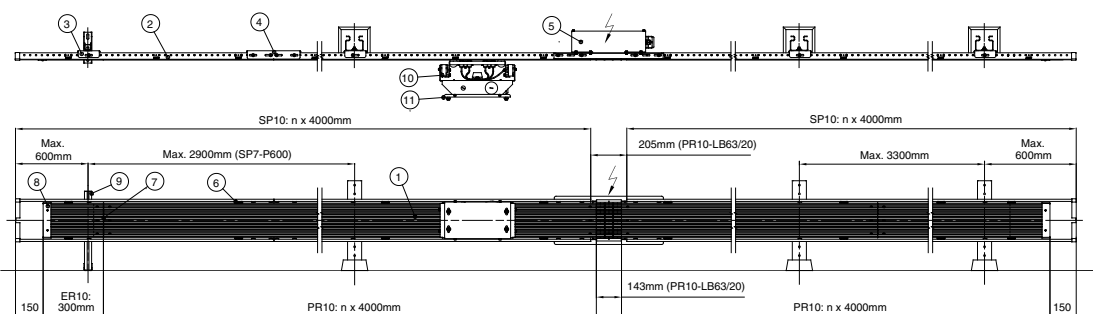

AKAPP conductor bar systems: always a perfect solution!

AKAPP Pro-Ductor is a very reliable and efficient conductor system, successfully used in many warehouses, but it is only one of our products.

Wabtec Netherlands supplies many more conductor systems, to create an optimal solution for each and every application. Whatever system you opt for, you can always count on the perfect functioning of the installation.

Wabtec Netherlands appreciates your interest in our products and our specialised personnel will be pleased to advise you, no strings attached and without any costs.

Would you like more information? One phone call, fax or e-mail will do. You will find the relevant details on the front of this brochure or visit our website www.akapp.com.

Multiconductor

A compact and multi purpose conductor system. The **uninterrupted** conductors ensure a perfect transmission of **current feed** as well as **control** and **data signals**. Current capacities from 35, 50, 80, 125 up to 160A. A flexible double sided rubber sealing prevents penetration of dust or liquids and allows functioning in extreme weather conditions. No expansion problems due to the clearance that exists between the conductors and the PVC housing. No effect on the performance of the system. Well suited for extremely long tracks and high travel speeds.

AKAPP Multiconductor is used world-wide for cranes, traverse cars, (automated) warehouses, elevators, textile production, sluices, trains etc., even under in extremely dusty, humid or even corrosive environments.

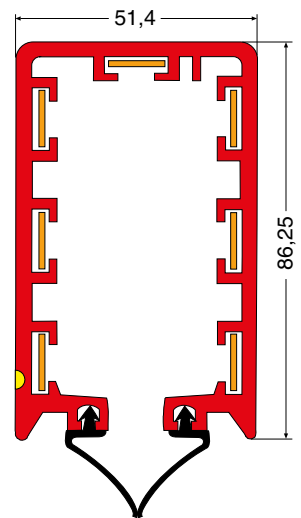

4-Ductor

If four conductors suffice, no flexible rubber sealing is required, but you do want to make use of all the advantages of the uninterrupted conductors, opt for the most ideal conductor system for your organisation, opt for the AKAPP 4-Ductor! Ideal, for it has: no expansion problems, a constant and low voltage loss, a choice of 5 current intensities (see above) and virtually no maintenance.

In all, an uninterrupted current supply for a variety of movable and/or mobile equipment at a **very profitable cost-benefit analysis**.

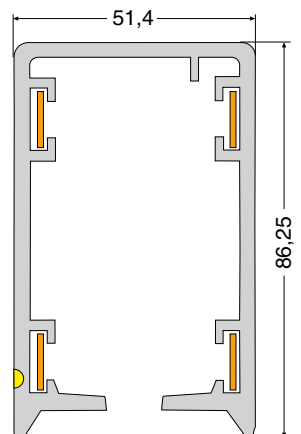

Wabtec Netherlands: Flexible with energy!



Wabtec Netherlands is a market leader with our made to order conductor bar systems. We offer you the best possible solution for almost any application in whatever the circumstances. We welcome your inquiries!



Our festoon systems offer the most flexible solutions for transporting flat or round cables and hoses. A wide variety of profiles and components guarantees reliable installations, adapted to the environment.



The AKAPP products are designed by the highest standards and are certified by UL, CCC and CE.

More information on our products can be found in our brochures, which we are happy to send you on request. Or visit our website www.akapp.com, where you can find more relevant information, download brochures and make online inquiries; fast and easy!

