

Pro-Ductor®

Insulated flat conductor bar
for 4, 7 or 10 conductors

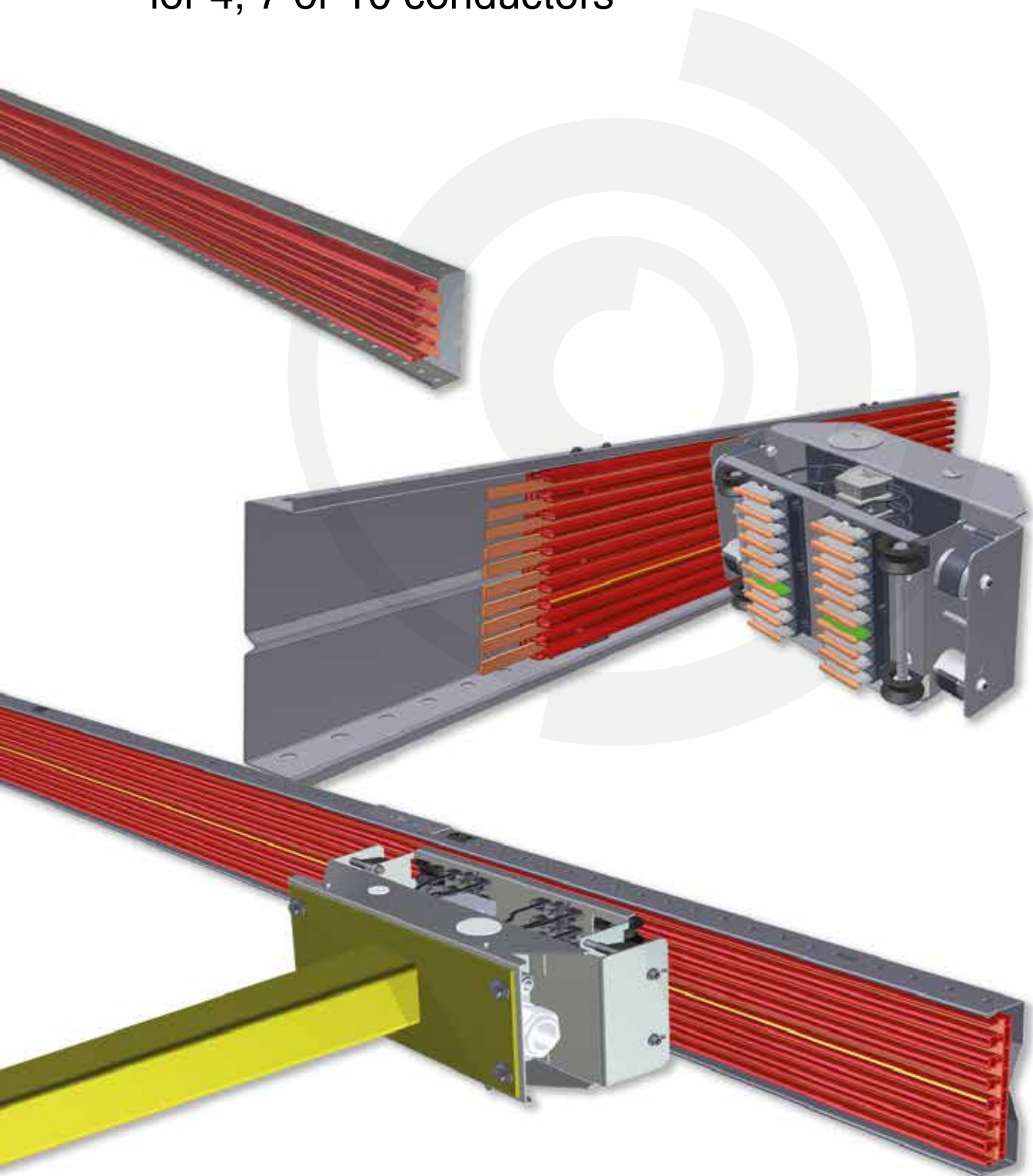

AKAPP Pro-Ductor®

- The ideal flat conductor system for automated warehouses and many other applications
- Current capacity 50A, 80A, 125A, 160A, 200A, 250A, 320A and 400A
- Housing up to 4, 7 or 10 uninterrupted conductors
- Usable at most heights
- Self-aligning collector trolleys
- High travel speeds up to 500 m/min possible.
- Highly suited to transmission of control and data signals
- Extremely low maintenance costs
- CE-approved and UL-certified



AKAPP Pro-Ductor conductor system is a unique concept, permitting the ultimate in possibilities and applications.

Pro-Ductor is specifically designed for use in automated warehouses, which are characterised by a range of extremely challenging demands.

Pro-Ductor offers many possibilities. An example is illustrated (left). Here you can see a Pro-Ductor installation in an automated high bay warehouse with an aisle changing crane.

Pro-Ductor® conductor systems:

The ultimate in design!

The Pro-Ductor system is specifically designed for heavy duty tasks performed in automated warehouses.

The standard length is 4 meter. Any length less than 4 meters is possible. Connecting the sections is done using the click and lock system. No drilling or screws!

Up to 4 conductors can be positioned in the channels within the PVC conductor housing PR4; up to 7 conductors within the PVC conductor housing PR7 up to 10 conductors within the PVC conductor housing PR10. The number and capacity of the conductors depend on the requirements. It is possible to combine conductors for feed and control.

The most important details are described in the section below.

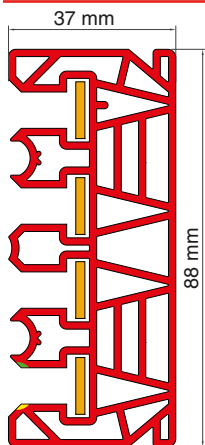

Housing PR4
with conductors

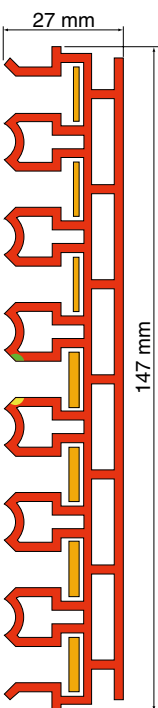

Housing PR7
with conductors

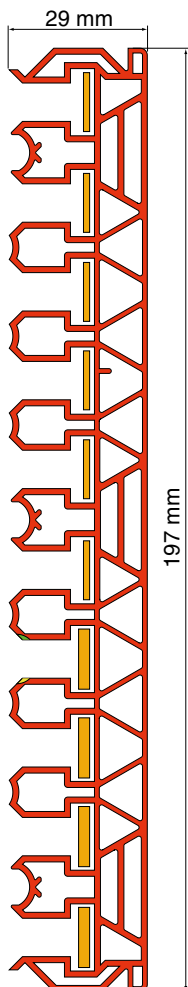

Housing PR10
with conductors

- ① **Housings with 4 (PR4) , 7 (PR7) or 10 (PR10) copper channels**
Due to the clearance between the conductors and their location, the copper channels offer sufficient room for up to 10 uninterrupted conductors, without plug connectors. Ideally suited for both control and data signal transmission. No expansion problems!
- ② **5 different types of copper conductors**
The flat copper conductors are available in 50A, 80A, 125A, 160A and 200A (80% D.C.). Parallel-mounted systems (PR7 and PR10) provide a maximum current capacity of 400A (80% D.C.)!
- ③ **Uninterrupted yellow/green earth-marking**
Clearly indicates the earth conductor. Safety!
- ④ **Wheel-guided collector trolley**
The perfect mechanical conduction enhances the life expectancy of the collector trolleys and brushes. It also ensures optimal transmission of line and control voltage.
- ⑤ **Easy installation**
The individual lengths (max. 4 m) can easily be connected to each other, after which the copper conductors are pulled through the channels.
- ⑥ **Compact construction**
With inclusion of the support profile SP4, the system measures 46 x 128 mm (for profile SP7 this is 45 x 165 mm and for profile SP10 this is 40 x 240 mm), making it suitable for most automated warehouses. Furthermore it can be installed, virtually at floor level!
- ⑦ **Double-walled housing**
This gives a considerable rigidity, allowing the distance of the suspension to be relatively large. When the steel support profile is used, a span of up to 3.30 m can be realised.
- ⑧ **Feed and control in a single housing**
Combine the feed strips with those for the control.
- ⑨ **Safety first!**
The PVC-housing is self-extinguishing and has a conspicuous red colour for additional safety. Furthermore the housing is contact safe (IP2X according to the standard IEC529).
- ⑩ **No expansion problems**
The copper conductors lie separately in each channel, so that these can expand and contract independently of the PVC housing.

Ultimate logistical control: uninterrupted feed at all times

For each Pro-Ductor installation, the flat copper conductors can be pulled from rolls into the previously installed PVC housing in long continuous lengths.

There are no connections in the conductor, which offers considerable advantages!

The fixed electric feed point can be placed at either the end or at random points in the installation.

Even if the latter option is chosen, the copper conductors are not interrupted!



What is the advantage of uninterrupted copper conductors?

- ① **Optimal contact**
The flat, smooth copper surface guarantees an optimal contact with the carbon brush.
- ② **No plug connectors**
The best method to reduce voltage loss is an uninterrupted copper conductor. This is essential when it concerns reliable transmission of control signals. No problem whilst working with AKAPP!
- ③ **Capacity extendable**
The installation can be extended at all times and at any moment. For instance, due to a changed situation additional or heavier copper conductors can be installed.
- ④ **Extremely low maintenance**
Due to the absence of plug connectors the surface of the copper conductors is extremely smooth, which ensures minimal brush wear. The copper conductors as well as the carbon brushes are therefore extremely low maintenance.
- ⑤ **Alternative strips**
Silver-plated copper strips can be installed in the copper channels, for use in extreme weather conditions or other challenging applications.
- ⑥ **Quick installation**
The strips can quickly and easily be pulled into the channels, using the copper cassette (see photograph) and a copper puller.

Arrangement of the copper conductors

A large number of combinations is possible, using the standard housings and 5 different copper conductors.

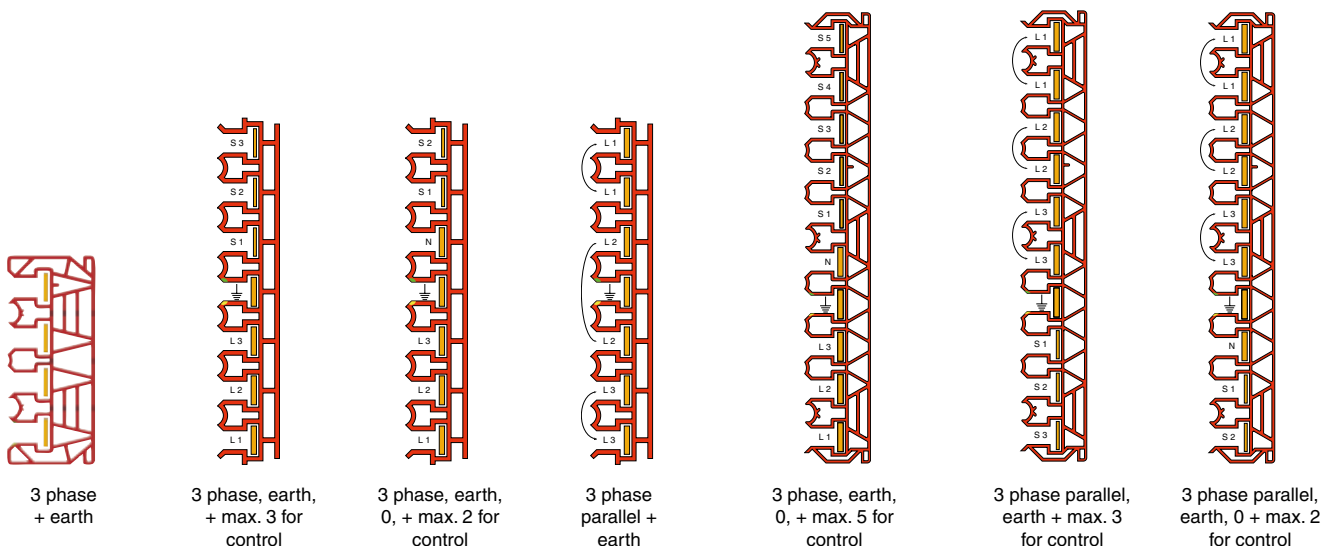

Pro-Ductor® feeding boxes: practical and easy ways to connect!

There are several possibilities for connecting feed- and control cables to a Pro-Ductor installation.

The cables can either be connected at a chosen point in the Pro-Ductor installation (line feed) or, in special cases, at the end thereof.

In most cases, a line feed can be applied as an end feed.

Pro-Ductor PR7 or PR10 can be applied when parallel mounting of the copper conductors is required, e.g. to increase the maximum current capacity or to decrease the voltage drop.

Pro-Ductor PR10 offers sufficient space for parallel mounted conductors for feed, combined with conductors for control functions.

See detailed descriptions in the section below.

Feed boxes (for all Pro-Ductor types).

Line feed boxes (normal connection):

Connects the feed cable (and/or control cable) at a chosen point or at the end of a Pro-Ductor system (see picture beside). Line feed boxes for PR4 systems are fitted with cable gland M63. Line feed boxes for PR7 and PR10 systems are fitted with cable glands M63 and M20.

A line feed box requires a clamp holder, including the required feed clamps, needed for mounting between two rail housing ends (see picture beside). The copper conductors can be connected easily and safely to the feed clamps. The copper conductors will not be interrupted.

Pro-Ductor housing with clamp holder and with line feed box on the back

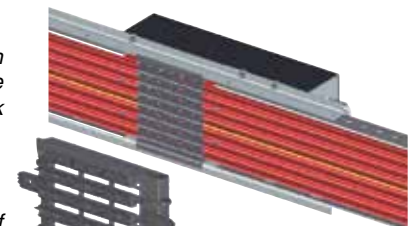

detail of clamp holder

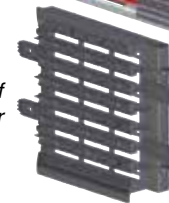

line feed box, mounted on support profile



Line feed boxes (parallel connection):

The same procedure as mentioned above, however there is a special clamp set available for parallel mounting, fitting within the clamp holder. It enables connection of the connection cable simultaneously to 2 copper conductors. See picture right.

line feed box with special clamp set for parallel connection of the conductors

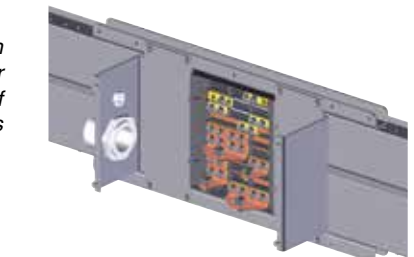

Feed boxes (for Pro-Ductor PR7 only).

End feed boxes (on request):

Connects the feed cable (and/or control cable) to the end of a Pro-Ductor system (see picture beside). The end feed box is fitted with cable glands M40 and M20. Provided with inserts for fast and reliable connection of the copper conductors using of the connecting bolts.

end feed (interior)

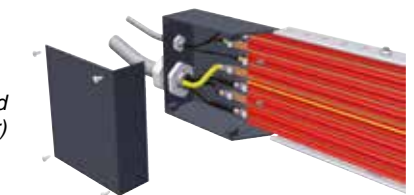

Special cable inlets on request.

Collector trolleys: excellent contact characteristics!

Pro-Ductor trolleys are available for a range of 2 to 10 conductors with current carrying capacities up to 63A and 125A nominal value. Duty cycle (DC) 80%.

As standard, the collector trolley can be used down to -30 °C , ideal for e.g. deep freeze storage cells.

Collector trolleys are fitted with terminals for cables up to 25 mm².

The uninterrupted copper conductors of the Pro-Ductor system enable high travel speeds (up to 500 m / minute!).

There are collector trolleys available for every application; not only for straight movements, but also for aisle changing cranes (see page 10).

① Automatic correcting system

The four leaf spring sets ensure the road wheels of the collector trolleys are kept in the section grooves. The trolley always follows its course perfectly.

② Perfect signal transmission

As a result of the optimal correcting characteristics the carbon brushes always glide straight on the flat, smooth copper conductors. This ensures optimal feed and control. Furthermore, each brush is equipped with a compression spring (see picture below).

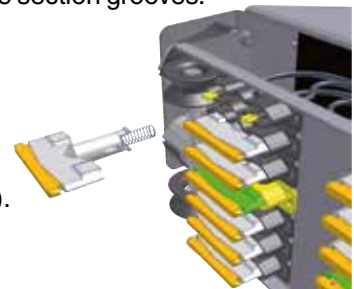

③ Quick installation

It is simple to mount the collector trolley to the mobile construction. The terminal box and the supporting profile both have the same height. This makes adjusting the collector trolley easy. Swinging of the warehouse crane during travelling is eliminated by the unique spring construction of the trolleys.

④ Steel terminal box

The trolley is fitted with a solid steel terminal box. Cables can be inserted from any side of the box. Apart from the standard cable gland M63 (type PCT4) or cable glands M63 and M20 (types PCT7 and PCT10), there are blind covered holes in the other 3 sides of the box, for cable glands.

⑤ Suited for curved tracks, switches and transfer switches

The collector trolleys can, without any problem, travel within or outside the rail section. For instance, when the crane travels from one aisle to the next. In order to maintain an uninterrupted signal the two collector trolleys can be switched parallel.

⑥ Very low maintenance

The road wheels and carbon brushes have minimum wear, since they are made of high quality, wear resistant, materials. This results in high reliability and performance, with minimal maintenance. The construction of the collector trolley permits quick and easy replacement of the wheels and carbon brushes.

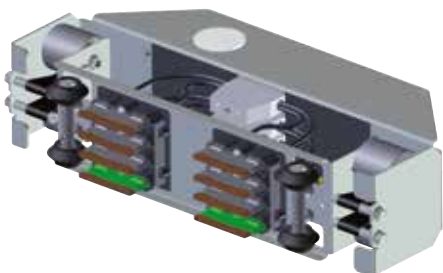

PCT4-4-125BI

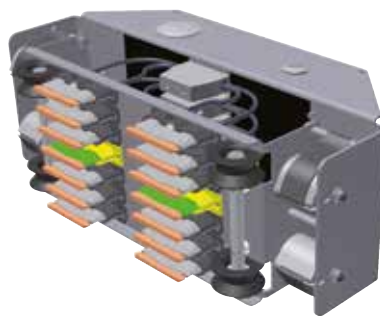

PCT7-7-125BI



PCT10-10-125BI-63-20

More on collector trolleys:

Leading edge design; optimal performance!

When developing the collector trolleys, reliability and durability were the most important issues.

The leading edge design, combined with the high quality components, form the basis for outstanding trolley performance.

Mounting and adjusting of the trolleys is very quick and easy.

The solid construction and easy alignment of the collector trolleys contribute to the extremely low wear, with optimal performance!

Mounting of the collector trolley

The collector trolleys are easily mounted to the moving apparatus using a mounting bracket (ordered separately). See picture.

The glands for the connection cables can be mounted on any of the sides of the steel terminal box by removing the appropriate blank hole.

After fixing of the mounting bracket, the trolley needs to be aligned.

Horizontal alignment

It is very important that the carbon brushes maintain the proper spring force when determining the exact length of the towing arm. See pictures to check the distances between towing arm end and the mounting bracket. A tolerance of 20 mm is permitted.

Vertical alignment

The height of the mounting bracket and the steel support profile are the same. This makes vertical alignment easy, e.g. by means of a level. A tolerance of 10 mm is permitted.

After alignment of the mounting bracket, the collector trolley can be mounted to it. Finally, the appropriate cables can be connected to the terminals.

Special collector trolleys

There are special types available for aisle changing cranes, which demand the use of transfer guides. See page 10 for more information about these applications.

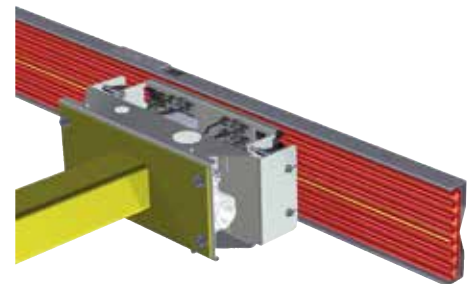

Collector trolley, mounted on the towing arm

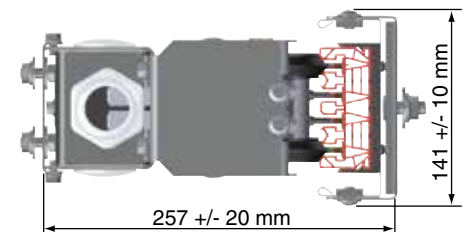

Mounting of trolley PCT4-x-125 on towing arm

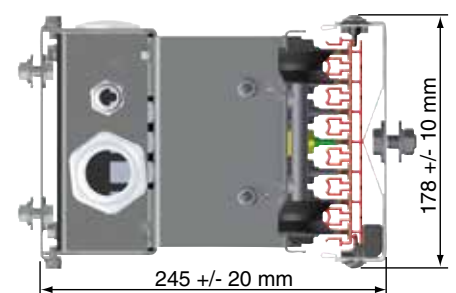

Mounting of trolley PCT7-x-125 on towing arm

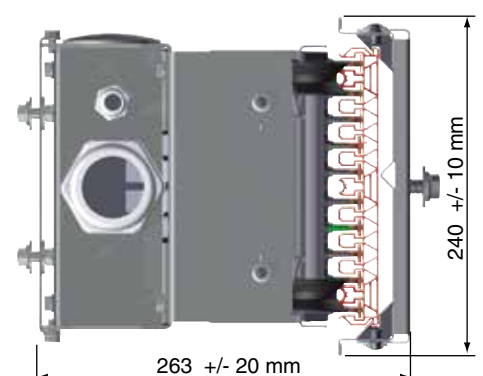

Mounting of trolley PCT10-x-125 on towing arm

AKAPP Pro-Ductor[®] conductor systems: efficiency per linear meter!

AKAPP Pro-Ductor saves costs. Saving starts immediately during installation. This because all components are tuned to each other, resulting in quick and efficient installation.

The Pro-Ductor housing is supported by the steel support profiles SP4, SP7 or SP10 and fits almost every application.

The support profile can, in most cases, be mounted directly on to the storage racks, without extra construction parts. Fast and easy mounting of the insulated Pro-Ductor housing is possible without using screws. Saving time and money during installation!

The solid support profile also protects the Pro-Ductor housing against falling subjects.

Suspension of rail section

The steel support profile (standard length 4 m) is easily fixed to the storage racks. In most cases the rail will be installed with the conductors below one another). The minimum mounting height is 160 mm (top PCT4), 200 mm (top PCT7) and 275 mm (top PCT10).

The shape of the support profile combines high rigidity with a low weight and minimal sizes. The sections are fitted with punched holes that allow free positioning of support brackets and/or joints for quick and easy installation. No welding, drilling etc. on site!

After mounting the support profile, the insulated Pro-Ductor housing can be fixed without using any tool!

The Pro-Ductor housing is supported along the complete track, providing high stability and allowing high travel speeds.

Up to 3.3 m between the various suspensions is possible, due to application of this supporting section. Without a supporting profile this distance is reduced to 0.8 m maximum.

Inspection of the collector trolley

Wabtec Netherlands ensured the possibility for a quick and easy inspection of the collector trolley.

Easy inspection of the collector trolley is achieved by removing it from its housing. Then, the carbon brushes, road wheels and wiring can be inspected at a glance.

Minimum brush wear is ensured, due to the smooth surface of the conductors and the absence of plug connections. The road wheels have minimum wear as well, since they are made of high quality, wear resistant, synthetic material.

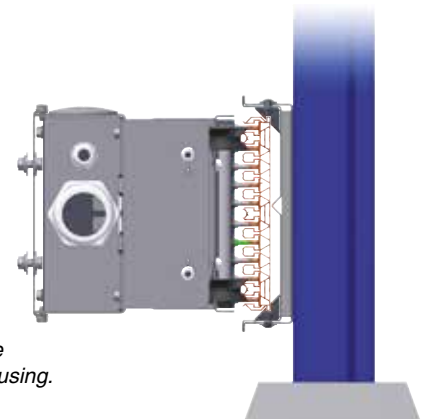

Supporting the Pro-Ductor housing.

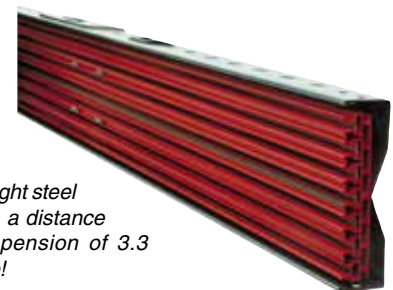

Due to the lightweight steel supporting profile, a distance between the suspension of 3.3 meters is possible!



For inspection, the collector trolley can be taken off the rail easy.



Replacing the carbon brushes.

Configuration of Pro-Ductor systems: some important remarks

Pro-Ductor systems offer a high level of mounting flexibility.

You can determine the most suitable location of the feed point (end- or line feed), considering the local situation and voltage drop.

The minimum mounting height is 160 mm (top PCT4), 200 mm (top PCT7 and 275 mm (top PCT10).

Support distances up to 3.30 metre are possible, provided that the steel support profile SP4, SP7 or SP10 is applied.

The graphics below show some typical configuration options for PR4, PR7 and PR10 systems. For more information on this please contact us.

① **System type PR4.**
Line feed

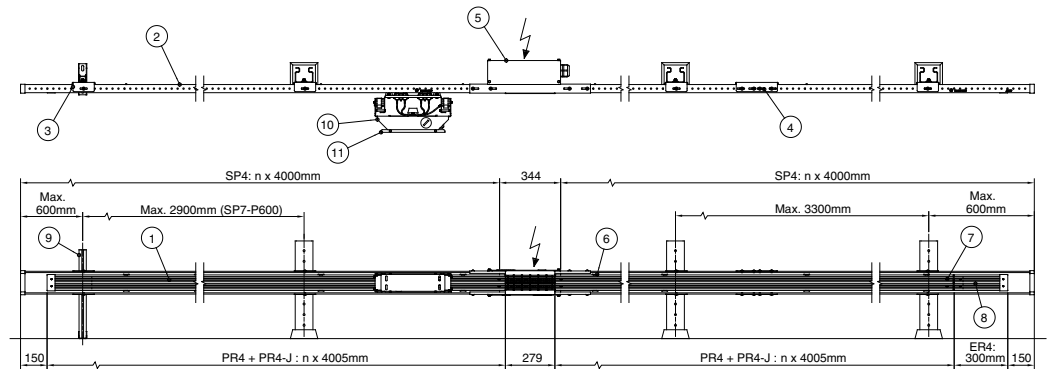

② **System type PR7/PR10.**
Line feed

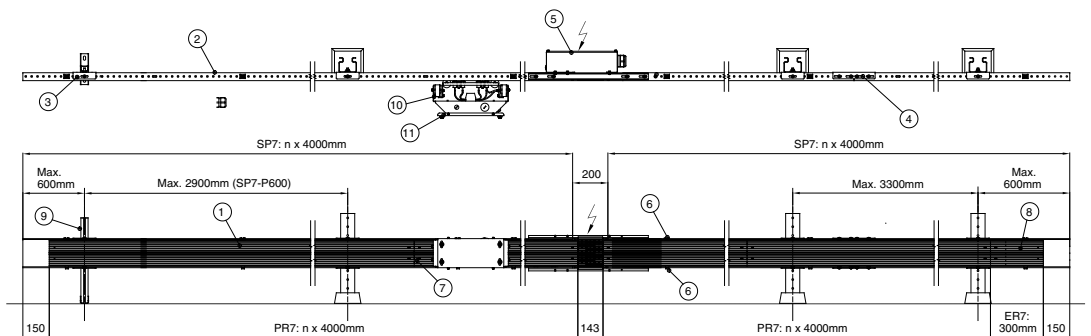

③ **System type PR7/PR10.**
Line feed as
End feed

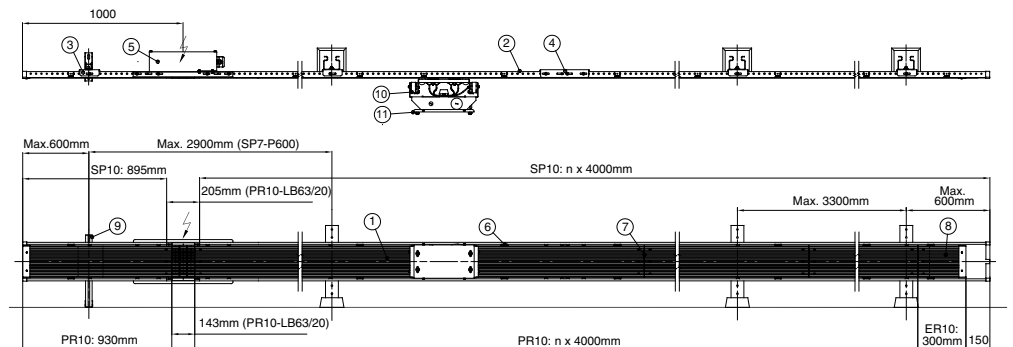

LEGENDE:

- | | |
|---|--|
| 1. Housing PR4/PR7/PR10 | 7. Joint for housing |
| 2. Support profile SP4/SP7/SP10 | 8. End cap |
| 3. Mounting bracket for support profile | 9. Support |
| 4. Joint for support profile | 10. Collector trolley |
| 5. Feed box | 11. Mounting bracket for collector trolley |
| 6. Mounting clip for housing | |

Special applications with Pro-Ductor®: even more possibilities!

The AKAPP Pro-Ductor system is extremely flexible and versatile because of the unique design.

It offers solutions for feeding problems in numerous applications, in a wide variety of circumstances.

Pro-Ductor systems can be applied for aisle changing (warehouse) cranes.

It is also possible to apply AKAPP Pro-Ductor systems in combination with electronic control systems, such as PROFIBUS®.

Advanced methods of positioning (e.g. with barcode) are also possible. The support profile can be extended with a special barcode strip.

Below are some examples.

Aisle-changers for Pro-Ductor (PR7/PR10)

Collector trolleys

An aisle changing crane must be fitted with 2 collector trolleys (63A), using a special guide construction. These trolleys are parallel mounted to prevent interruption of the current while the crane is changing from aisle.

Transfer guide sections

At the end of each aisle is a curved transfer guide, while in the main aisle straight transfer guides must be installed. These transfer guides are needed to lead the collector trolleys smoothly into the other track.

The crane can approach transfer sections from both sides, so the travelling direction is not relevant.

The travelling speed at the transfer guide may not exceed 80 m/minute.

Positioning systems for Pro-Ductor (PR4/PR7/PR10)

Barcode tape

An optical measurement system operating with a visible red light laser, commonly known as DOPS (Digital Optical Positioning System)

A metal strip provided with barcode tape is mounted on the top or below the support profile SP4, SP7 or SP10. The laser fitted on the (warehouse) crane reads the barcode and determines the crane position relative to the barcode tape.

Depending on the operating system, this information can be sent through the Pro-Ductor system to a processor for further use with additional software.

Please contact our sales office for further information on this and other positioning systems that can be combined with AKAPP Pro-Ductor.

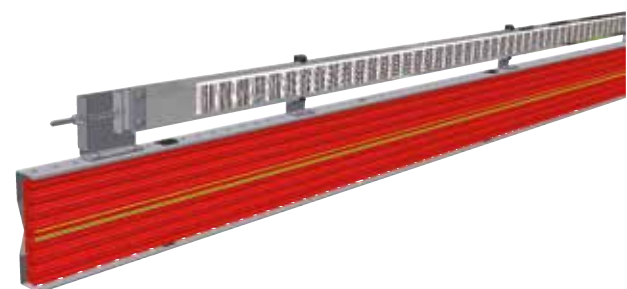
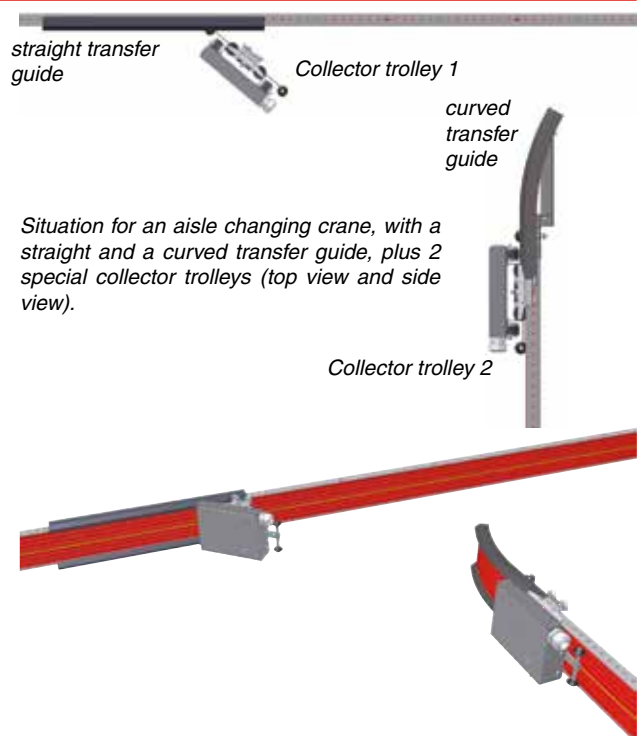

Example of a Pro-Ductor system with positioning by means of barcode strip.

AKAPP conductor bar systems: always a perfect solution!

AKAPP Pro-Ductor is a very reliable and efficient conductor system, successfully used in many warehouses, but it is only one of our products.

Wabtec Netherlands supplies many more conductor systems, to create an optimal solution for each and every application. Whatever system you opt for, you can always count on the perfect functioning of the installation.

Wabtec Netherlands appreciates your interest in our products and our specialised personnel will be pleased to advise you, no strings attached and without any costs.

Would you like more information? One phone call, fax or e-mail will do. You will find the relevant details on the front of this brochure or visit our website www.akapp.com.

Multiconductor

A compact and multi purpose conductor system. The **uninterrupted** conductors ensure a perfect transmission of **current feed** as well as **control** and **data signals**. Current capacities from 35, 50, 80, 125 up to 160A. A flexible double sided rubber sealing prevents penetration of dust or liquids and allows functioning in extreme weather conditions. No expansion problems due to the clearance that exists between the conductors and the PVC housing. No effect on the performance of the system. Well suited for extremely long tracks and high travel speeds.

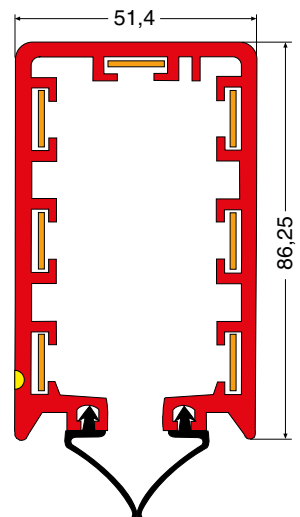

AKAPP Multiconductor is used world-wide for cranes, traverse cars, (automated) warehouses, elevators, textile production, sluices, trains etc., even under in extremely dusty, humid or even corrosive environments.

4-Ductor

If four conductors suffice, no flexible rubber sealing is required, but you do want to make use of all the advantages of the uninterrupted conductors, opt for the most ideal conductor system for your organisation, opt for the AKAPP 4-Ductor! Ideal, for it has: no expansion problems, a constant and low voltage loss, a choice of 5 current intensities (see above) and virtually no maintenance. In all, an uninterrupted current supply for a variety of movable and/or mobile equipment at a **very profitable cost-benefit analysis**.

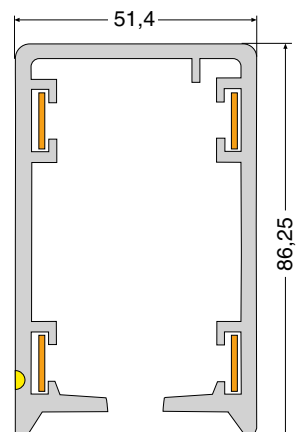

Wabtec Netherlands: Flexible with energy!



Wabtec Netherlands is a market leader with our made to order conductor bar systems. We offer you the best possible solution for almost any application in whatever the circumstances. We welcome your inquiries!



Our festoon systems offer the most flexible solutions for transporting flat or round cables and hoses. A wide variety of profiles and components guarantees reliable installations, adapted to the environment; from large harbour cranes to service stations.



The AKAPP products are designed by the highest standards and are certified by UL, CCC and CE.

More information on our products can be found in our brochures, which we are happy to send you on request. Or visit our website www.akapp.com, where you can find more relevant information, download brochures and make online inquiries; fast and easy!

