

POWERFEED SYSTEMS

MECHANICAL HANDLING

SAFETY SYSTEMS

OFFSHORE DIVISION

MECHANICAL HANDLING



Metreel

OTHER METREEL PRODUCTS & SYSTEMS...

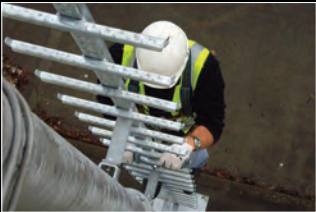

FALL ARREST LADDERS



CABLES



CABLE/HOSE REELING DRUMS



OFFSHORE DRAG CHAINS



FALL ARREST / ABSEIL



ELECTRICAL CONTROL



FESTOON SYSTEMS



OFFSHORE FESTOONS



FALL ARREST WIRE SYSTEMS



CONDUCTOR SYSTEMS



DRAG CHAINS



OFFSHORE CABLE BOOMS

THE COMPANY...

Founded some 40 years ago, **Metreel** are the leading supplier of Enclosed Track Materials Handling Systems. Our knowledge and experience with enclosed track has led to the development of our extensive programme of profiles and fittings, known as **MET-TRACK®**.

Primarily used for Lifting and Conveying in the form of light cranes, monorails and conveyors the **Met-Track®** system has numerous other applications such as workstation cranes, jib cranes, A frame gantries, tooling track, sliding door gear, playground equipment, fall arrest systems, abseil systems and cradle suspension systems to name but a few.

In addition to the many high quality products we offer within our standard range, Metreel also have a significant capacity for bespoke solutions. A dedicated design team utilising 3D CAD software can offer a design service from concept to final product.

Metreel regard the requirements of customers as its highest priority and to ensure that this is achieved we operate under the quality standard ISO9001, certified by SATRA.

Metreel have always strived to push the boundaries in all areas of our operations and as a measure of our success, have been awarded a number of achievements, some of which are listed below:-

- Company of the Year
- Excellence in Marketing
- Export Growth
- Offshore Industry Award
- Safety Product Innovation Award

This brochure presents an overview of the products we offer and should you require any further information please do not hesitate to contact our sales team or email at sales@metreel.co.uk.

INDEX...

LIGHT CRANES	1 - 14
JIB CRANES	15 - 16
OTHER TRACK SYSTEMS	17
BALANCERS / HEAVY DUTY WINCHES	18
PORTABLE ALUMINIUM GANTRIES	19 - 20





INTRODUCTION...

MET-TRACK® Workstation Bridge Cranes enable you to achieve effortless and reliable area-serving overhead handling for a wide variety of applications. Each system is configured with the operator in mind and includes the principle feature of ease of movement, designed to reduce fatigue and ensure accurate load positioning.

Our range includes both ceiling and floor mounted workstation bridge cranes, monorails and jib cranes.

Quality materials and construction ensure operational reliability and safety and facilitate long life combined with minimum maintenance.

Customer Designed Solutions

As a supplier of major materials handling projects worldwide, we are well experienced in dealing with turnkey installations where traditional overhead cranes are not feasible or practical. We believe that providing the customer with all the required systems configured exactly to their needs is essential to ensure the installed project is 'fit for purpose'. If you have a project and would like to take advantage of our experience then simply contact our sales team for further information.

SYSTEM FEATURES...

- Loads up to 2000 kg
- Bridge lengths up to 10m
- Gantry supports up to 9m
- Kit form
- Low cost
- Simple to install and extend
- Large range of mounting options
- Mixed capacity systems
- Bridge buffers
- Telescopic bridges
- Cantilever bridges
- Motorised tractor units
- Track transfer units

TYPICAL APPLICATIONS...

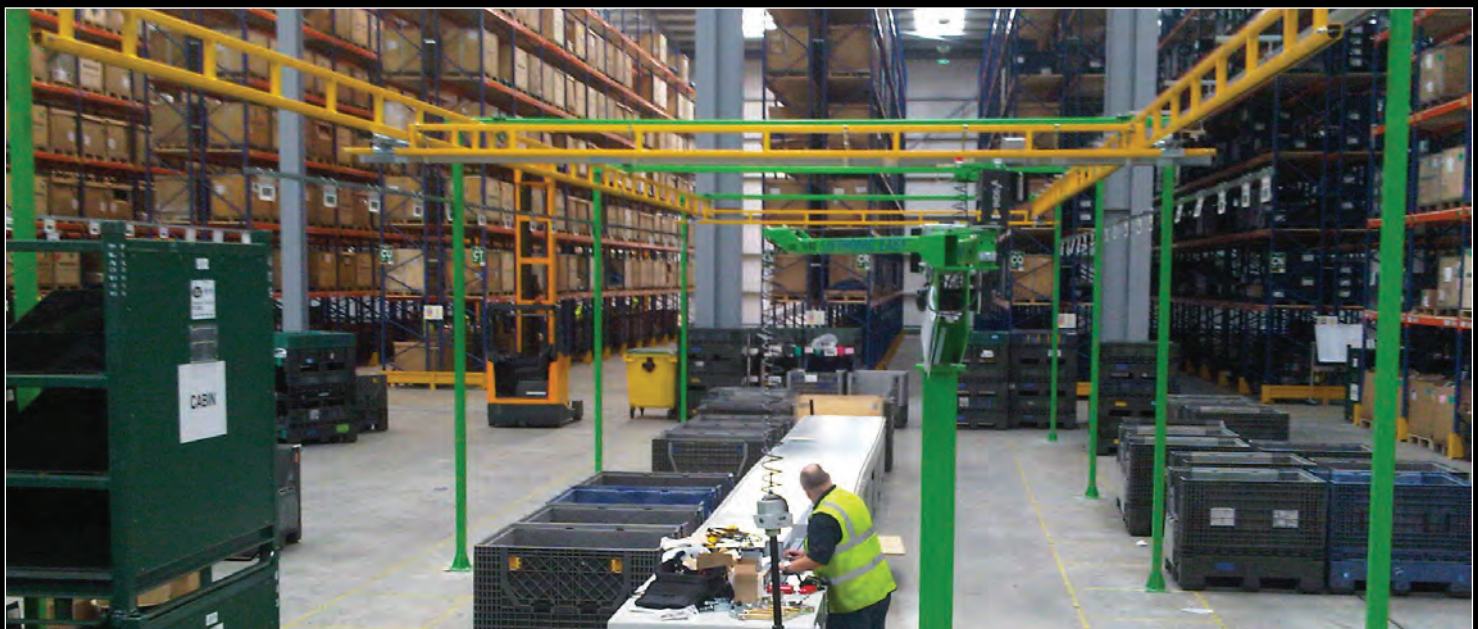

FEATURES...



Enclosed Track Profiles Make For An Ergonomic Design

The **MET-TRACK**® steel track design is one of high strength and low weight by combining the running track profile with standoff reinforcement to considerably increase span distances. The 'V' shaped profile of the running track ensures alignment of the trolleys and end carriages and also prevent dirt accumulation inside the tracks.

Machined wheels with crowned tread and precision sealed bearings fitted ensure absolute minimum rolling resistance and provide long operational life.

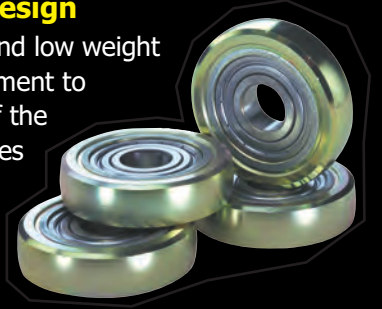

System Features:

- Four running track profiles to select from – 400, 500, 600 and 700 Series
- Long spans allow systems to be installed with the minimum of supports, maximising the work cell layout
- Enclosed track cranes are up to three times easier to move than traditional bridge cranes
- Small sized profiles for bridges, gantrys and headers allow systems to be installed where headroom is a problem

Easy Installation And Modular Design

The **MET-TRACK**® pre-engineered modular design allows for easy relocation and/or expansion by simply adding gantry sections and/or additional bridges.

Splice joints connect the track sections and are complete with vertical and horizontal adjustment screws, facilitating precise alignment of the track sections.

Floor mounted cranes can be installed on any normal 150mm reinforced concrete floor. Depending on structural capabilities, our systems can be ceiling mounted reducing the impact on floor space.



GANTRY PROFILES...

Capacity (kg)	Profile	Spine Style	Maximum Span (mm)	Running Track	UDL Load (kg/m)	Weight (kg/m)
125	400M	Plain	1800	400	5.5	0.33
	CIAB460	Trussed	6000	400	6.2	0.71
	CIAB475	Trussed	7500	400	4.7	0.74
250	500M	Plain	1800	500	17.9	0.53
	CIAB560	Trussed	6000	500	11.8	1.13
	CIAB575	Trussed	7500	500	10.0	1.18
	CIAB590	Trussed	9000	500	9.1	1.20
500	600M	Plain	1800	600	41.4	0.82
	CIAB660	Trussed	6000	600	22.3	1.68
	CIAB675	Trussed	7500	600	20.0	1.74
	CIAB690	Trussed	9000	600	16.0	1.79
1000	700M	Plain	1800	700	120.0	1.53
	CIAB760	Trussed	6000	700	59.0	3.02
	CIAB775	Trussed	7500	700	37.6	3.06
	CIAB790	Trussed	9000	700	34.9	3.19
2000	CIAB860	Trussed	6000	700	121.0	3.55
	CIAB875	Trussed	7500	700	78.8	3.60
	CIAB890	Trussed	9000	700	Enquire	3.69

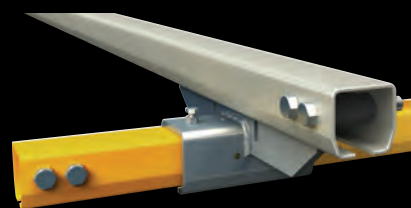

PLAIN GANTRY



TRUSSED GANTRY

BRIDGE PROFILES...

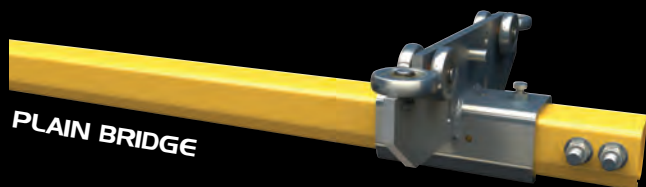

PLAIN BRIDGE

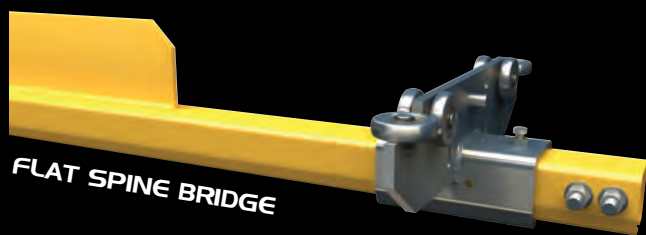

FLAT SPINE BRIDGE



TRUSSED BRIDGE

Capacity (kg)	Profile	Profile	Max CBL (mm)	Running Track	Weight (kg/m)
125	400M	Plain	1800	400	0.33
	400F	Flat Spine	3000	400	0.89
	BR411	Trussed	4500	400	0.60
	BR412	Trussed	6000	400	0.65
	BR413	Trussed	7000	400	0.67
	BR414	Trussed	8500	400	0.86
250	500M	Plain	1800	500	0.53
	500F	Flat Spine	3000	500	1.10
	BR511	Trussed	4500	500	1.00
	BR512	Trussed	6000	500	1.05
	BR513	Trussed	7000	500	1.07
	BR514	Trussed	8500	500	1.12
500	BR515	Trussed	10000	500	1.37
	600M	Plain	1800	600	0.82
	600F	Flat Spine	3000	600	1.39
	BR611	Trussed	4500	600	1.48
	BR612	Trussed	6000	600	1.56
	BR613	Trussed	7000	600	1.59
1000	BR614	Trussed	8500	600	1.65
	BR615	Trussed	10000	600	2.21
	700M	Plain	1800	700	1.53
	700F	Flat Spine	3000	700	2.13
	BR711	Trussed	4500	700	2.70
	BR712	Trussed	6000	700	2.84
2000	BR713	Trussed	7000	700	2.89
	BR714	Trussed	8500	700	3.01
	BR715	Trussed	10000	700	3.10
	BR811	Trussed	4500	700	2.95
	BR812	Trussed	6000	700	3.22
	BR813	Trussed	7000	700	3.24
	BR814	Trussed	8500	700	3.67

DESIGN & ERGONOMIC CONSIDERATIONS...

Height..

In order to reduce the operational resistance to an absolute minimum we recommend that the trolley load pin height (LPH) is kept as low as possible with practical considerations applied to the minimum headroom requirements. LPH is measured from the top of the trolley load pin from which the hoist / lifting device is suspended.

Bridge Length...

Keep the bridge length to a minimum, but bear in mind that the active travel for each bridge length is restricted due to the end stops and trolley lengths. Ensure your selected kit provides you with required active travel.

Working Load...

The working load must be selected according to each application task. Although the effort to move the crane bridge is small it can be further reduced by selecting the lightest size / weight of the system to suit the application i.e. for a 180kg maximum load select a 250kg capacity and not 500kg.

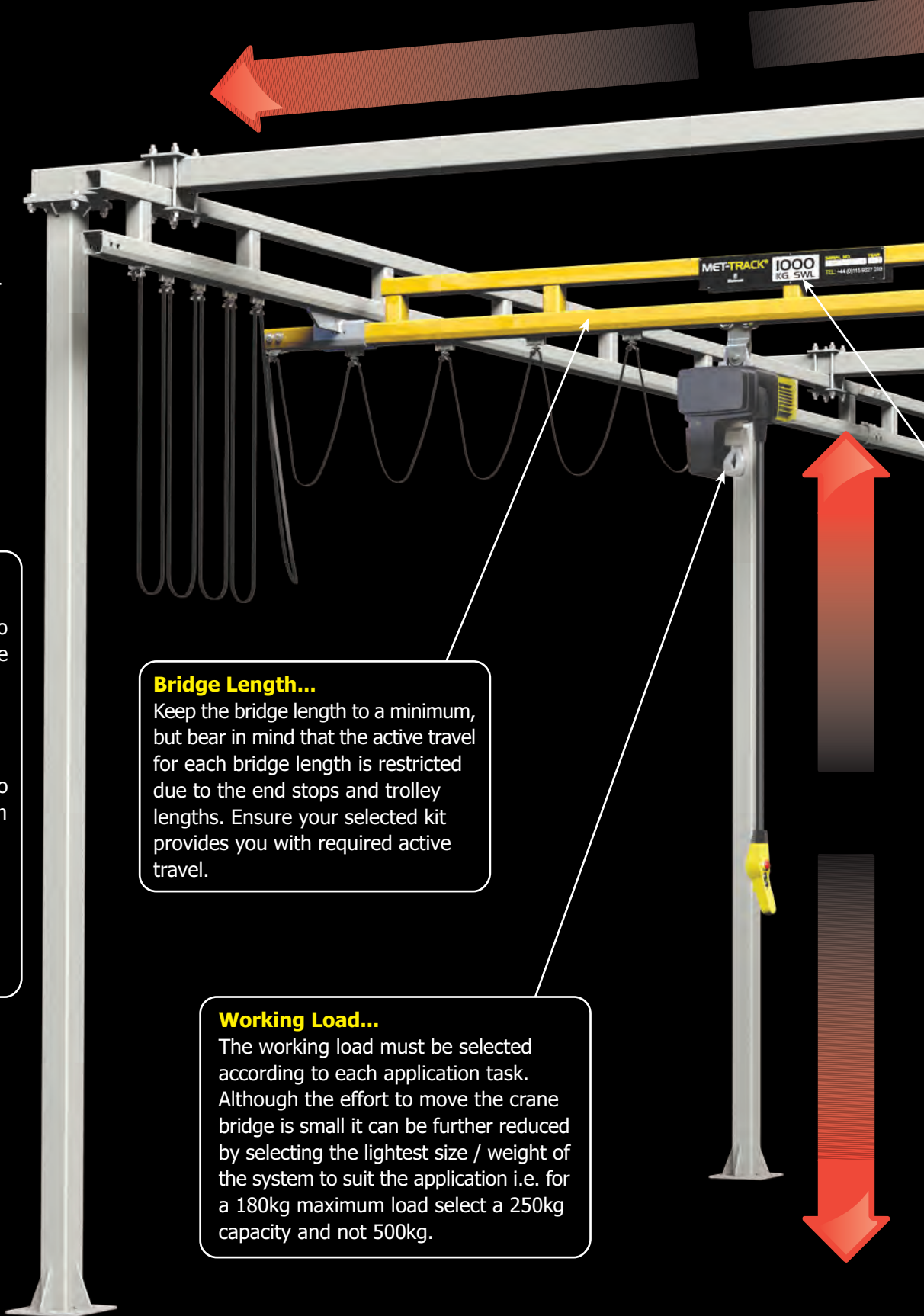

**Gantry Length...**

The length of the gantry is unlimited and solutions can be provided for supports of up to 9m.

For ceiling mounted systems 1.8m supports are also available.

Rated Capacity...

The capacity is the live load that can be lifted by the crane system. The workstation crane is designed with an allowance of 15% for the weight of the hoist and the trolley; therefore a 500kg bridge includes the allowance covering the combined hoist and trolley weight of up to 75kg.

LIGHT CRANES

BASIC CRANE...

The **MET-TRACK**® crane system consists of bridges, gantrys, gantry joint kits, end carriages, hoist trolleys and end bolts. These basic components can then be supported by standard floor mounted structures, ceiling mounted assemblies or special arrangements according to the application requirements. In addition, it is possible to add either cable, hose or vacuum festoons or conductor bar systems to enable powerfeed for the chosen lifting device.



FLOOR MOUNTED CRANE...



Our **Floor Mounted** Crane Systems, once installed, are not a permanent part of your building structure and can easily be removed and relocated to accommodate for future changes in your production facility.

FLOOR MOUNTED MONORAIL...



Using the same profiles as the crane gantrys we also have a complete range of monorail capacities. We can offer either a single line configured monorail or one with curves, switches and turntables to form a closed loop facility for such as paint line etc. These can also be floor or ceiling mounted

CEILING MOUNTED CRANE...

Ceiling mounted systems are ideal when floor space is limited or access by other equipment is required where floor support steels would normally be needed. This option does require that the support structure is suitable for the loads imposed and Sway Bracing is generally required.



FLOOR MOUNT ASSEMBLIES...

- Flush mount hanger assemblies
- Low weight headers for easier handling during installation
- Adjustment both laterally and longitudinally



CEILING MOUNT HANGER ASSEMBLIES...

- Flush mount or dropper style hanger assemblies
- Wrap around or double saddle clamp arrangements



Drop Rod

Plain/Trussed Gantry:
Parallel or Perpendicular 500mm or 1800mm



Flush Mount

Plain Gantry: Parallel or Perpendicular

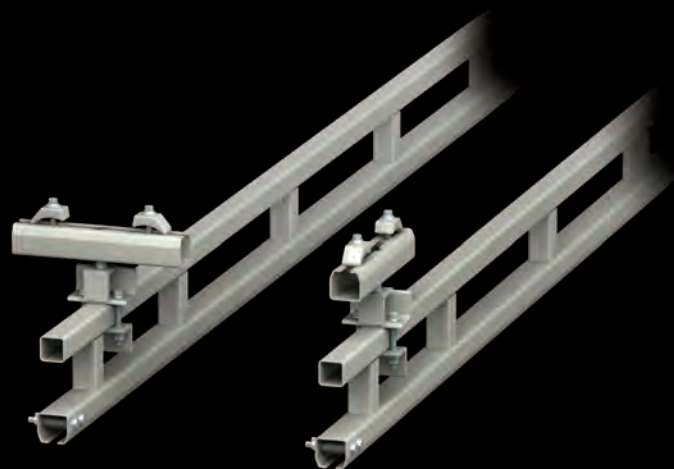

Flush Mount

Trussed Gantry: Parallel or Perpendicular



Sway Bracing

Ceiling mounted kits require sway bracing in all circumstances except where the gantry is flush mounted to the support steelwork.

COMPONENTS...



End Clamp

Fitted at the end of the crane bridge and at the end of the gantry festoon section. Utilised as standard on all systems with festoon power supply.

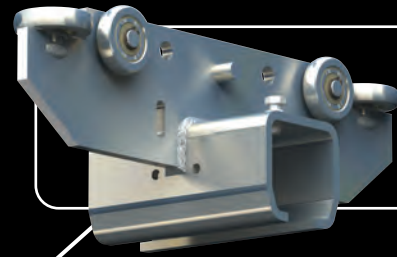

End Carriage

Provides a smooth and gantry track. Prevents against 'crabbing'.

Festoon Trolley

Utilised on power hoist systems for carrying the flat/round cable or hose from the static source to the moving hoist or bridge.



Splice Kits

Connect the top chord of the gantry and align tracks sections for precise connection.

Optional Conductor System - Please See The Relevant Chapter Within This Brochure

both running connection between the bridge
. The horizontal side guidance wheels guard
g action'.



End Stop
Fastened through the track, the end stop arrangements are fitted with resilient rubber bumpers which safely absorb impact forces at the track ends (standard on all systems).

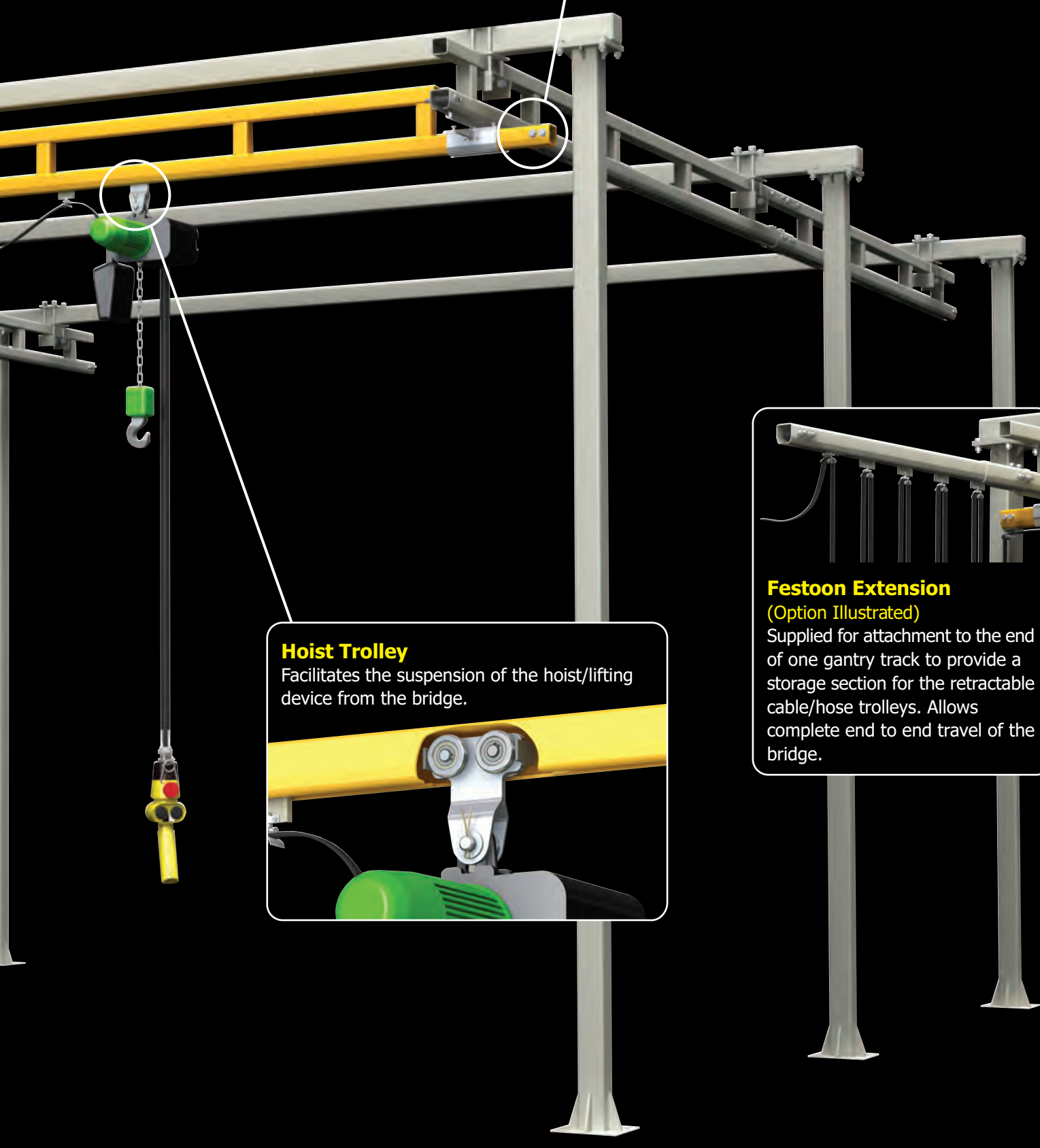

Hoist Trolley
Facilitates the suspension of the hoist/lifting device from the bridge.

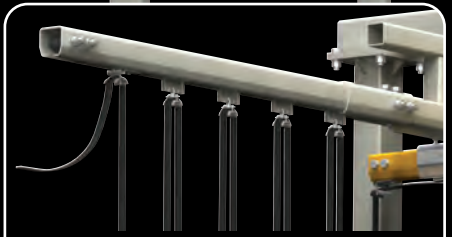

Festoon Extension
(Option Illustrated)
Supplied for attachment to the end of one gantry track to provide a storage section for the retractable cable/hose trolleys. Allows complete end to end travel of the bridge.

GANTRY & BRIDGE CONDUCTOR SYSTEMS...

The principle of a workstation bridge crane is to make the work of a user easier by designing the system to move freely. When power is required to the lifting equipment it is traditional that standard festoons provide this function.

As a standard upgrade option, the **MET-TRACK®** system can be fitted with our **4DUCTOR**, enclosed conductor bar system instead of a festoon. This is ideal in applications where the festoon loops and storage may pose a problem or not be suitable and is recommended for multiple bridge systems. This simple to add system offers no resistance to the easy movement of a workstation crane but benefits the installation of end to end travel removing the need for festoon storage.

Features Of 4DUCTOR:

- Continuous Copper Conductors
- Range of Standard Capacities
- Minimum Brush Wear
- Totally Enclosed Profile
- Simple to Install & Maintain
- Easily extendable for future extension of the system

Conductor Capacity	up to 4
Current Capacities	50, 80, 125A
Protection:	IP23
Housing Lengths:	2m and 4m
Temperature Range:	-30°C to +60°C
Maximum Speed:	60m/min

Bridge Travel With 4DUCTOR® Compared To Festoon System



BRIDGE CONFIGURATIONS...

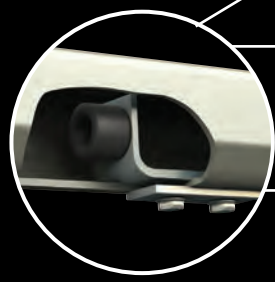

Intermediate Stops

This means each bridge is isolated into a separate span which reduces the need for heavier gantry tracks.

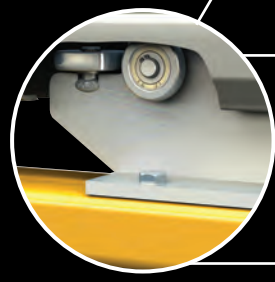
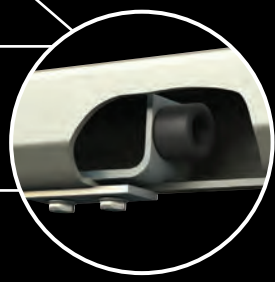

Bridge Buffers

Bridge buffers are suspended from two trolleys in the gantry to create a predetermined minimum distance the bridges can operate from each other.

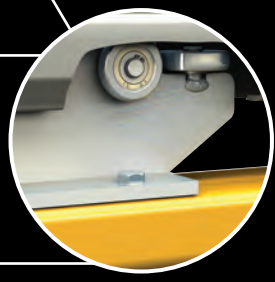

Mixed Capacity

Multiple bridges can be used with mixed capacities with only the gantry steelwork having to be of a heavier design i.e. two 250Kg bridges can work anywhere when installed on 500Kg gantry kits.

OPTIONS...

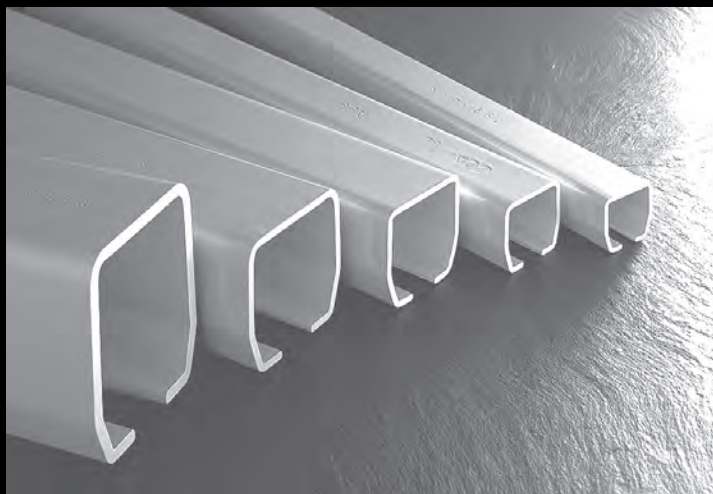

Profiles

The **MET-TRACK**® Enclosed Track is the principal element of the handling solutions we offer, it is particularly suited for cranes, jib cranes, monorails and conveyors, but can be utilised for many other applications. Five standard tracks offer a lifting capacity of up to 2000kg utilising a variety of lifting devices.

Available in standard or special finishes, including 3 profiles in stainless steel, the **MET-TRACK**® system offers the customer the option to customise any installation appearance.

The high strength/low weight factor of the tracks reduce the need for expensive steelwork which in turn simplifies installation and future system modifications.



Curves

A complete range of curves offer ultimate flexibility for any conveyor or monorail system. When planning a system that requires bends we always advise utilising standard radii if possible, however for those applications which dictate special radii, these are also an option.

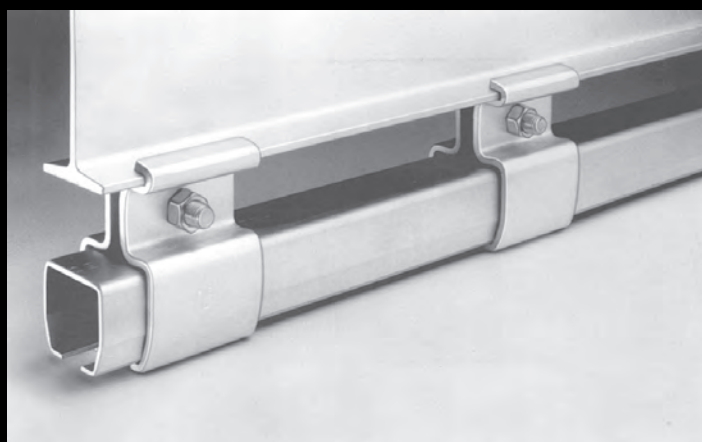

Support Brackets

A wide range of standard support brackets to suit most building constructions and supporting steelwork is available. In the event of a requirement for special mounting, we have the capability to design special manufactured items completely to customers requirements.

When considering any system and the method of mounting, it is essential that the roof, ceiling or floor structure is of adequate strength for the proposed system. We recommend consultation with a qualified structural consultant to advise in this area.

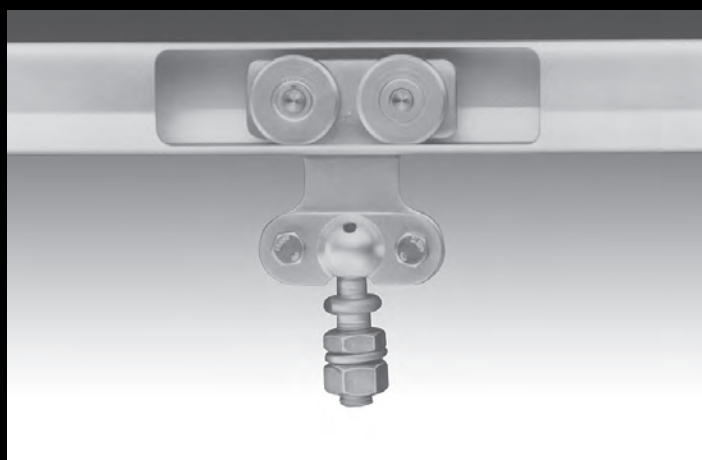

Suspension Trolleys

A vast selection of two, four and eight wheeled suspension trolleys offer connection to endless possibilities of equipment being transported.

Free running sealed wheels are a standard feature of **MET-TRACK**®. Special options such as waterproof and high temperature are also available. The design of our profiles protect the wheels and ensure minimum friction for the complete range of our suspensions trolleys.

OPTIONS...

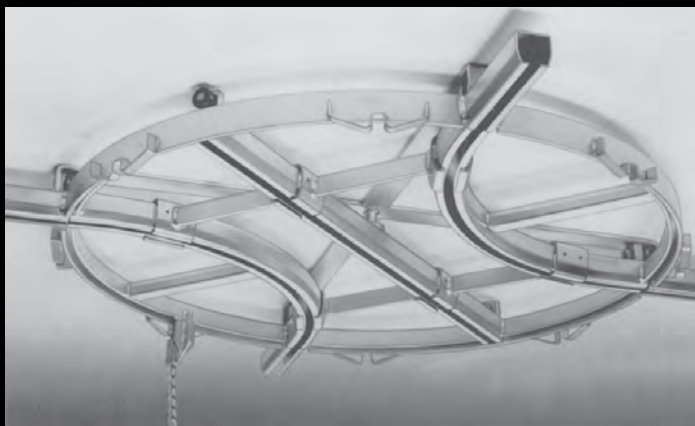

Turntables

The use of standard turntables and multi directional units at track joints will add greater flexibility to any monorail or conveyor system. All the **MET-TRACK®** turntables rotate freely on precision ball bearings and are easily operated and positioned using one of several control mechanism options.

Standard turntables provide interconnection for up to four tracks, however additional connections can be incorporated.

Mechanically operated turntables are recommended for applications where the work flow is moderate and intermittent. For applications requiring continuous flow we recommend the use of our multi-directional units which feature a range of settings according to production requirements.

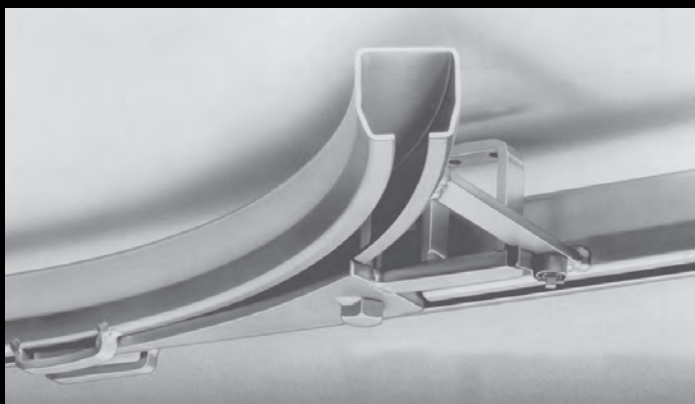

Switches

Designed to facilitate branching off from the main line conveyor or monorail track. Two types of standard switches are available, the Swivel Switch offers a maintenance free, easy to operate solution. The basic element is a pivoting track section which incorporates a mechanical stop to close off the inoperative track.

The alternative, a Tongue Switch, is a compact design which gives a particular advantage when several branch lines are required in close proximity. The basic element is a tongue guide which is suited to either manual or automatic operation.

Our switches are normally manually operated, however they can be assisted by electric, pneumatic or hydraulic power.

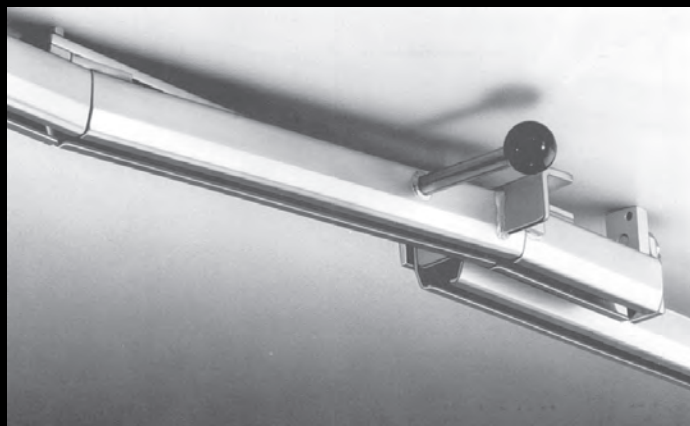

Entry/Exit Section

This unit operates in a similar way to the swivel switch and facilitates the insertion/removal of trolleys at a required position, ideally suited for a closed loop system where work flow can increase and decrease and suspension trolley quantity needs to be modified.

The basic element is a pivoting track section which incorporates a mechanical stop to close off the open end.

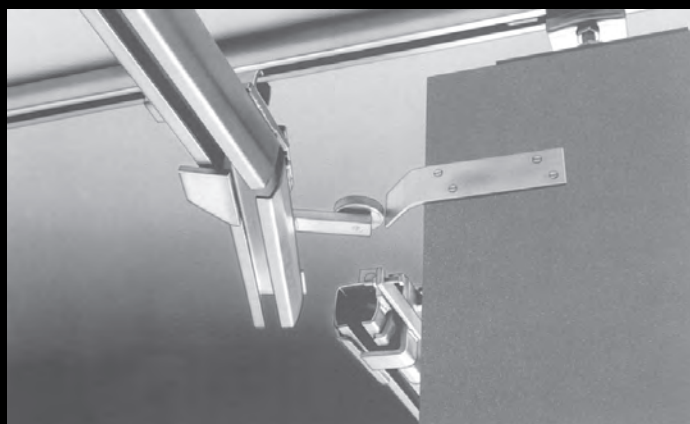

Door Swivel Section

The door swivel section enables the track to be interrupted automatically by a sliding door for reasons of security or emergency. Typical examples being cold room or fire protection doors.

Safety devices are incorporated to ensure that the trolleys cannot disengage from the track during operation.

INTRODUCTION...

Our Workstation Jib Cranes provide up to 360° coverage and are supplied as underbraced or overbraced. They are the perfect handling solution for supporting tool balancers, air balancers, hoists, vacuum lifters and welding wire feeders.

The Jib Arm rotation and trolley travel are both smooth and effortless allowing users maximum control with minimal effort, increasing productivity giving companies a prompt return on the investment. The superior ease of movement means the user force required to operate the Jib Crane is so low, that safety is increased and injuries are minimised.

Ease Of Movement

The **MET-TRACK**® Jib Cranes have far superior movement and positioning over the traditional I-Beam Jib Cranes. The high strength / low weight factor of the track contributes to the ease of movement along with the profile design, which incorporates a self cleaning feature, offers wheel protection and accurate alignment with minimal friction. High quality free running sealed wheels are fitted to all trolleys as standard.

Ease Of Rotation

The high strength / low weight factor of the Jib Construction weigh less than traditional I-Beam Jibs, therefore the rotation requires far less force. This minimal jib arm weight combined with precision tapered bearings or bronze brushes with oilite thrust washers combine to produce effortless rotation.

Precision Load Positioning

The combination of the free moving trolleys, and ease of boom rotation make the **MET-TRACK**® Jib Cranes an excellent solution for positioning and placing loads.

Quiet Heavy-Duty Wheels

Machined wheels with crowned tread and precision sealed bearings fitted ensure absolute minimum rolling resistance and provide long operational life.

Ready For Powered Hoisting

MET-TRACK® Jib Cranes are supplied with a hoist trolley as standard. A factor of 15% of the Jib capacity has been allowed for hoist weight. A further 25% factor has been applied for impact, covering speeds of up to 15m/min.

Large Range Of Spans / Capacities

Our standard range of **MET-TRACK**® Jib Cranes have been designed to cater for the majority of the applications by covering a large range of spans and capacities, all detailed within this brochure. This ensures all the lead times and costs involved with customization are avoided.

UNDERBRACED JIB CRANES...

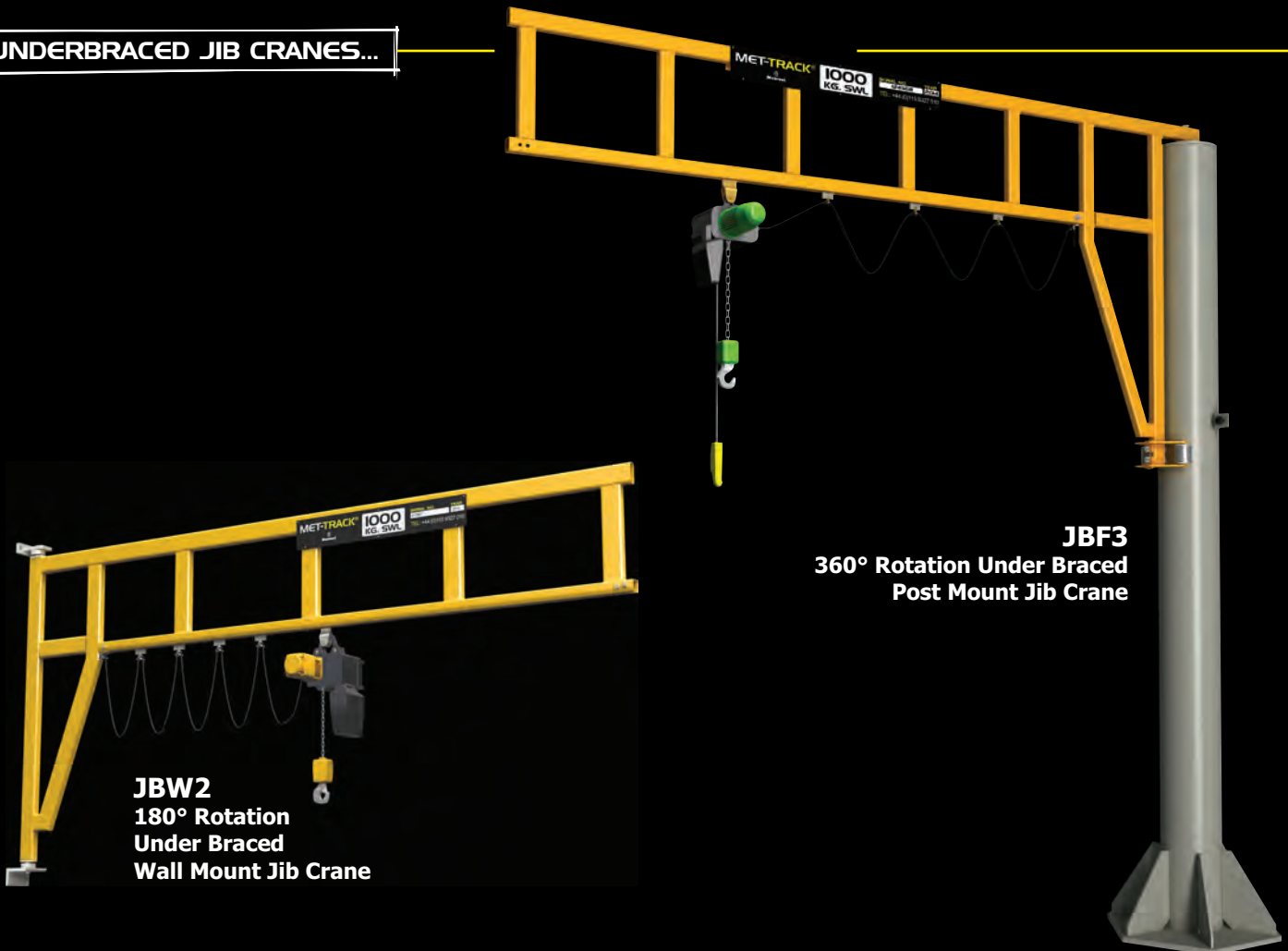

JBW2
180° Rotation
Under Braced
Wall Mount Jib Crane

JBF3
360° Rotation Under Braced
Post Mount Jib Crane

OVERBRACED JIB CRANES...

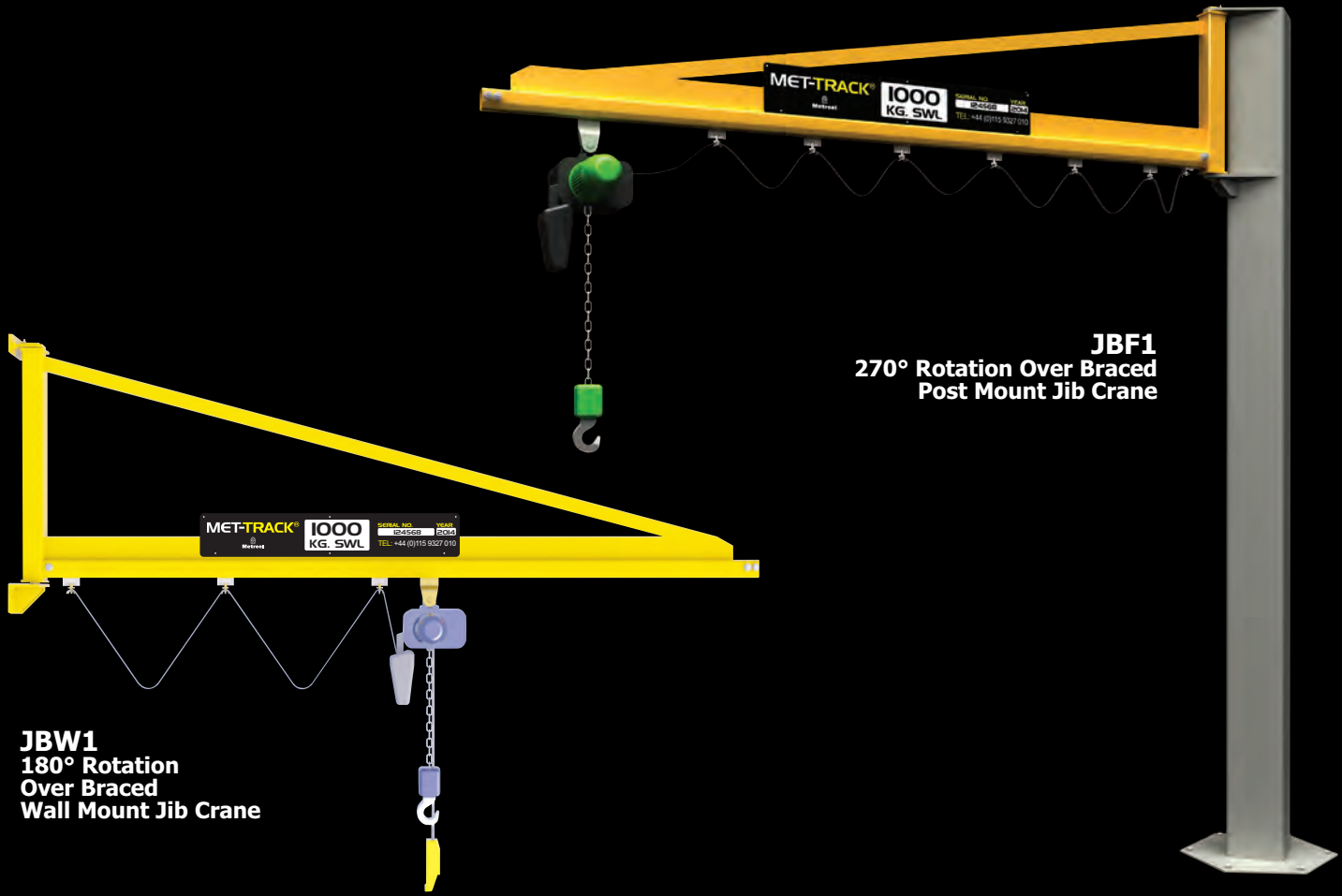

JBF1
270° Rotation Over Braced Post Mount Jib Crane

JBW1
180° Rotation Over Braced Wall Mount Jib Crane

ACCESSORIES...



Tagline Festoon

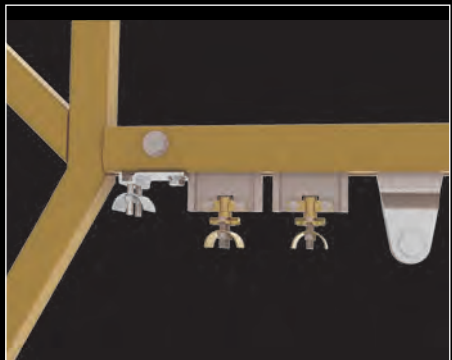

In Track Festoon

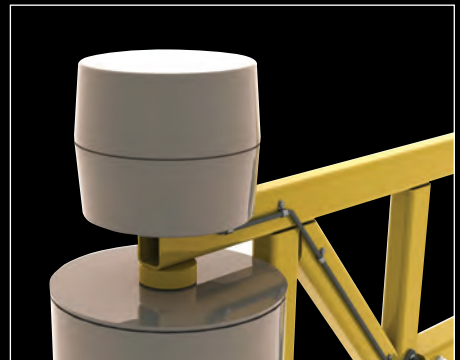

360° (or continuous) Rotation



Rotational Stop

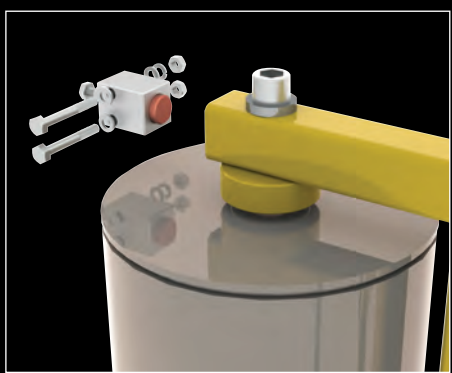

Friction Brake

OTHER TRACK SYSTEMS

INTRODUCTION...

MET-TRACK® track systems can be used in many other applications, in addition to the main applications shown on the previous pages.

Typical applications for **MET-TRACK®** track systems are illustrated in this section. Specific literature is available for some of the more popular uses, such as Horizontal Fall Arrest and Sliding Door Gear.

The high strength/low weight factor of the tracks reduces the need for expensive support structures, in turn this offer advantages for customer who have headroom restrictions.

The profile design, which incorporates a self cleaning feature, offers wheel protection and accurate alignment with minimum friction.

High quality free running sealed wheel units are also possible for specific applications - please consult our sales office

SYSTEM FEATURES...

- Loads up to 2000kgs
- A choice of 7 track profiles
- Special finishes available, including stainless steel
- Power and free options available
- Kit form options
- Low Cost
- Simple to intall and extend
- Large range of mounting attachments
- Minimum Maintenance

CUSTOM DESIGN & BUILD...

Customer: Royal College of Surgeons **Brief:** To design a quad bridge gantry system suspending 8 mobile service boxes allowing the College maximum flexibility of room layout. This gantry system facilitates all types of training whether it be individual, working in pairs or small groups. Each service box houses multiple feed plugins which included audio visual RCD inputs, network connections, 240v power points, compressed air, water, and suction. One of the main stipulations for this project was aesthetics, the system had to look state of the art with no visable feeds showing.



SLIDING DOOR GEAR...

MET-TRACK® Sliding Door Gear are rated for loads up to 2000Kgs and are extremely reliable system for the suspension of all types of industrial, commercial, agricultural and domestic sliding doors.

Seven track profiles to choose from with a range of standard and special finishes, including hot-dip galvanised steel, stainless steel and various other coatings.

Typical features of the **MET-TRACK®** Sliding Door System are fine setting adjustments, which are designed into the track and door suspension brackets plus the profile design which combines the features of wheel protection, accurate alignment and minimum friction.



TOOL BALANCERS...



Metreel Retractors are designed in such a way that retraction force increases as the cable is extended. As a result the attached tool is returned to its starting position by the retractor after use, leaving the workbench free for other tools or items of equipment. An assurance of precision work is provided by the shallow rising graph representing the progressive increase in spring force.

Metreel Balancers are distinguished by their conical cable drum which ensures that the retraction force remains virtually 'constant', regardless of the cable travel. As a result, the position is retained after the attached tool has been used. In addition, no noteworthy increase in retraction force occurs when delicate operations are being performed. As a result, **Metreel** balancers permit fatigue free working, even over prolonged periods of time.



LUG-ALL PORTABLE WINCH HOISTS...



Metreel are the UK Agents for **LUG-ALL™** offering a complete range of CE approved portable wire rope winch hoists with Safe Working Loads up to 1800kgs capacity. **LUG-ALL™** portable winch hoists are manufactured with a strong ultra light aluminum frame, holding self storing aircraft steel wire rope, a reversible safety handle and a unique interlocking pawl system.

Innovative Design

- Light weight aluminum alloy frame
- Aircraft Grade wire rope – no heavy chains
- Unique method of anchoring wire
- Reversible handle, for ease of use
- Self storing Aircraft Grade wire rope (No set up required)
- Drop forged steel hooks

Reliable Design

- Factory tested to 50% overload
- Handle bends on severe overload
- Quick Release facility
- Removable handle
- One year guarantee

4 Models:

1000-15SH-UK
Single Wire lift 350Kg

3000-10SH-UK
Single Wire lift 500Kg
Double Wire lift 1000Kg

4000-20SH-UK
Single Wire lift 700Kg
Double Wire lift 1400Kg

6000-15SH-UK
Single Wire lift 900Kg
Double Wire lift 1800Kg



ALU-LIFT® PORTABLE ALUMINIUM GANTRIES

OVERVIEW...

ALU-LIFT® Portable Aluminium Gantries are the ultimate in lightweight construction for ease of portability. These gantries are ideal when you require constant assembly and disassembly, such as use by site personnel or for emergency lift in a difficult location.

Breakdown

The **ALU-LIFT®** has been designed to breakdown and pack into compact transportable size.

Transportation Straps

The **ALU-LIFT®** is supplied with two securing straps to help with storage / transportation

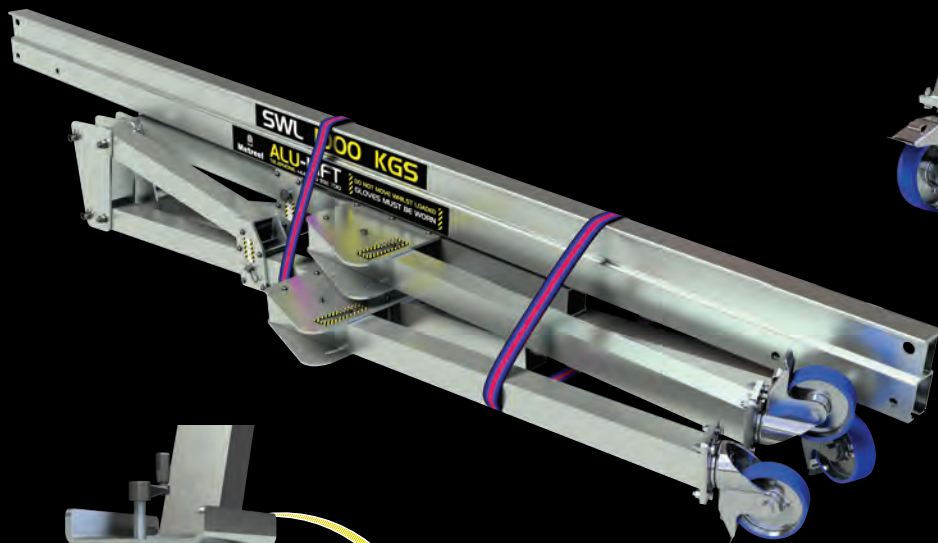

Optional Jack Up Assemblies

Developed to solve the associated issues caused from operating on uneven ground.

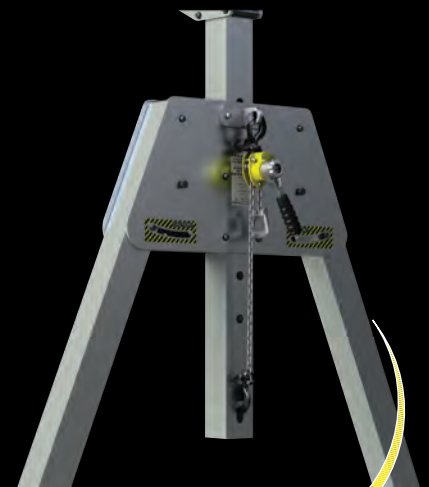

Optional Winch Kit

To aid safety and usability when raising & lowering the overall height of the unit.

ALU-LIFT BUILD PROCESS...



ALU-LIFT DIMENSIONAL DETAILS AND PART NUMBERS...

SWL (Kg)	Model Number	Height	Span (A)	Widths Between Support Plates	Height to Underside of Beam		Beam Depth (D)	Beam Width (E)	Beam to Load Pin (F)	Width with Legs Out (G)	Beam Weight (Kg)	Total Weight (Kg)
					Max	Min						
500	AL0502520	2500	2000	1270	2500	2000	190	80	78	1490	21.6	128
	AL0502530		3000	2270	2500	2000	190	80	78	1490	32.4	139
	AL0502540		4000	3270	2500	2000	270	80	78	1490	56.4	163
	AL0502550		5000	4270	2500	2000	270	80	78	1490	70.5	177
	AL0503020	3000	2000	1270	3000	2500	190	80	78	1490	21.6	149
	AL0503030		3000	2270	3000	2500	190	80	78	1490	32.4	160
	AL0503040		4000	3270	3000	2500	270	80	78	1490	56.4	184
	AL0503050		5000	4270	3000	2500	270	80	78	1490	70.5	198
	AL0503520	3500	2000	1270	3500	3000	190	80	78	1490	21.6	192
	AL0503530		3000	2270	3500	3000	190	80	78	1490	32.4	203
	AL0503540		4000	3270	3500	3000	270	80	78	1490	56.4	227
	AL0503550		5000	4270	3500	3000	270	80	78	1490	70.5	241
1000	AL1002520	2500	2000	1270	2500	2000	190	80	78	1490	21.6	128
	AL1002530		3000	2270	2500	2000	270	80	78	1490	42.3	149
	AL1002540		4000	3270	2500	2000	270	80	78	1490	56.4	163
	AL1003020	3000	2000	1270	3000	2500	190	80	78	1490	21.6	149
	AL1003030		3000	2270	3000	2500	270	80	78	1490	42.3	169
	AL1003040		4000	3270	3000	2500	270	80	78	1490	56.4	184
	AL1003520	3500	2000	1270	3500	3000	190	80	78	1490	21.6	192
	AL1003530		3000	2270	3500	3000	270	80	78	1490	42.3	213
	AL1003540		4000	3270	3500	3000	270	80	78	1490	56.4	227
2000	AL2002520	2500	2000	1270	2500	2000	270	80	78	1490	28.1	135
	AL2002530		3000	2270	2500	2000	270	80	78	1490	42.3	149
	AL2003020	3000	2000	1270	3000	2500	270	80	78	1490	28.1	155
	AL2003030		3000	2270	3000	2500	270	80	78	1490	42.3	169
	AL2003520	3500	2000	1270	3500	3000	270	80	78	1490	28.1	199
	AL2003530		3000	2270	3500	3000	270	80	78	1490	42.3	213

OPTIONAL EXTRAS

Winch Kit: Includes 1x AL-26962 Tie Down Bracket and 1x AL-YK-250 Lever Hoist

Optional Jack Up Assemblies: AL-26963

POWERFEED SYSTEMS

- Festoon Systems
- Standard & Custom Reeling Drums
- Cable & Hose Drag Chains
- Conductor Systems
- Collector Columns
- Flexible Cables
- Plug & Sockets
- Pendant Control Stations
- Radio Remote Pendants
- Worm Gear Limit Switches
- Foot Switches

SAFETY SYSTEMS

- Vertical Fall Arrest Ladder Systems
- Safetrack Horizontal Track Systems
- Horizontal Wire Systems

MECHANICAL HANDLING

- Met-Track® Light Cranes
- Met-Track® Monorails & Conveyors
- Met-Track® Sliding Door Gear
- Met-Track® Custom Track Systems
- Alu-Lift® Portable Aluminium Gantry
- Tool Balancers

OFFSHORE DIVISION

- Cable & Hose Drag Chains
- Cable & Hose Festoon Systems
- Cable & Hose Booms
- Cable & Hose Reeling Drums

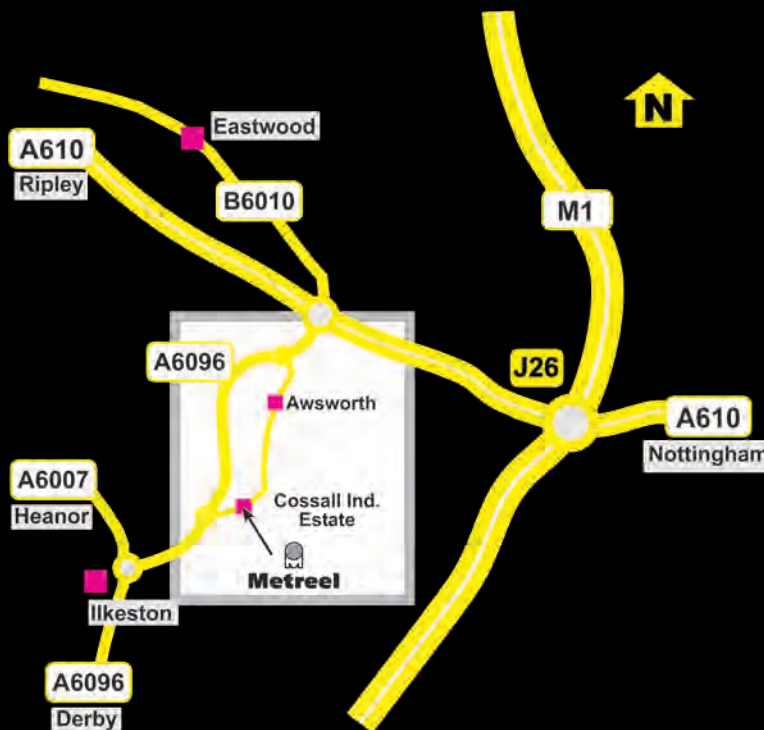

CONTACT DETAILS:



+44 (0) 115 932 7010



+44 (0) 115 930 6263



sales@metreel.co.uk



www.metreel.co.uk



Metreel

Cossall Industrial Estate, Coronation Road,
Ilkeston, Derbyshire DE7 5UA